

FEATURES

- High Accurate $\pm 2\%$
- Precision monitoring of +3V, +3.3V, and +5V Power supply voltage
- Fully specified over temperature
- Available in three output configurations
- Push-Pull RESET low output (MAX809)
- Push-Pull (RESET) high output (MAX810)
- 200ms typ. Power-on reset pulse width
- 25 μ s supply current
- Guaranteed reset valid to $V_{CC}=+1V$
- Power supply transient immunity

The MAX809/810 series are used for microprocessor (μ P) supervisory circuits to monitor the power supplies in μ P and digital systems. They provide excellent circuit reliability and low cost by eliminating external components and adjustments when used with +5V, +3.3V, +3.0V, +2.5V powered circuits.

These circuits perform a single function: they assert a reset signal whenever the V_{CC} supply voltage declines below a preset threshold, keeping it asserted for at least 200ms after V_{CC} has risen above the reset threshold. Reset thresholds suitable for operation with a variety of supply voltages are available. MAX809/810 series have push pull outputs. MAX809 series has an active low

APPLICATION

- Battery-operated systems and controllers
- Intelligent instruments
- Critical μ P and μ C power monitoring
- Portable / Battery powered equipment
- Automotive

RESET output, while the MAX810 has an active high RESET output. The reset comparator is designed to ignore fast transients on V_{CC} , and the outputs are guaranteed to be in the correct logic state for V_{CC} down to 1.0V. Low supply current makes MAX809/810 series ideal for use in portable equipment.

Ordering Information

MAX810L

RESET VOLTAGE: L=4.63V
M=4.38V
J=4.00V
T=3.08V
S=2.93V
R=2.63V

Marking:

MAX809L: AAAA
MAX810L: AGAA
MAX809M: ABAA
MAX810M: AHAA
MAX809J: CWAA
MAX809T: ACAA
MAX810T: AJAA
MAX809S: ADAA
MAX810S: AKAA
MAX809R: AFAA
MAX810R: ALAA

TYPICAL APPLICATIN CIRCUIT

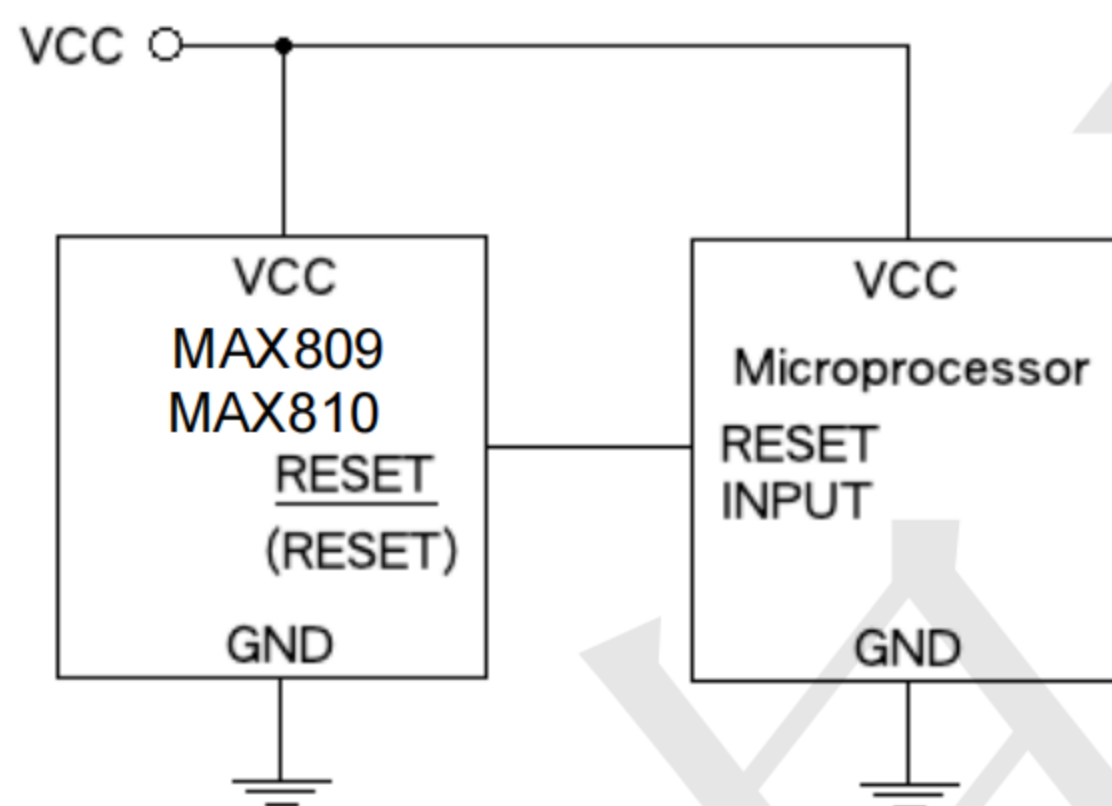

Pin Definition

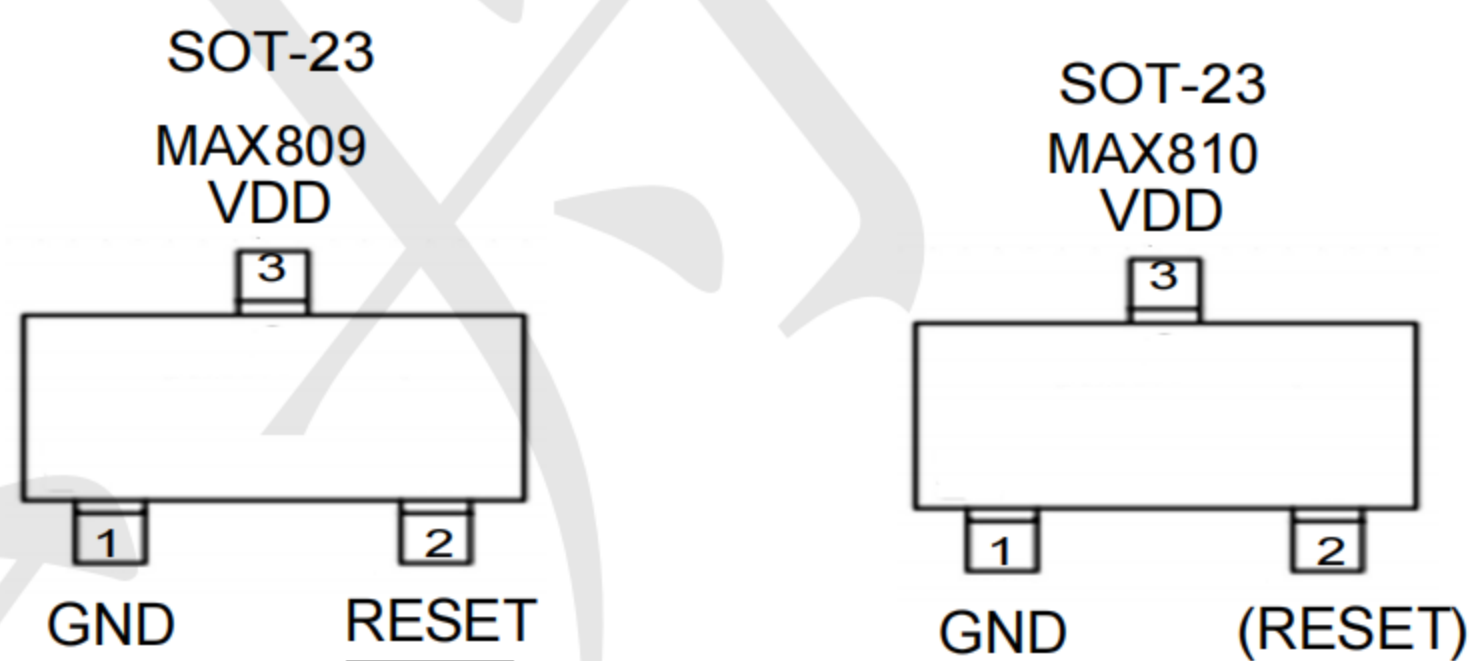

ABSOLUTE MAXIMUM RATINGS

PARAMETER	SYMBOL	LIMIT	UNIT
Terminal Voltage (with respect to GND)	V_{CC}	GND - 0.3 to GND +6.5	V
<u>RESET</u> & (RESET) push-pull	V_{RESET}	GND - 0.3 to V_{CC} +0.3	V
Input Current, V_{CC}	I_{CC}	20	mA
Output Current, <u>RESET</u> , (RESET)	I_O	5	mA
Power Dissipation	P_D	$(T_J - T_A)/R_{\theta JA}$	mW
Operating Junction Temperature Range	$T_{J.OPR}$	-40 ~ +125	°C
Storage Temperature Range	T_{STG}	-65 ~ +150	°C
Lead Soldering Temperature (260°C)	T_{LEAD}	10	s

THERMAL PERFORMANCE

PARAMETER	SYMBOL	MAXIMUM	UNIT
Thermal Resistance from Junction to Case	$R_{\theta JC}$	110	°C/W
Thermal Resistance from Junction to Ambient ^(Note 1)	$R_{\theta JA}$	250	°C/W

ELECTRICAL CHARACTERISTICS ($V_{CC} = 5V$, $T_A = 25^\circ C$ unless otherwise noted)

PARAMETER	CONDITIONS	SYMBOL	MIN	TYP	MAX	UNIT
Input Supply Voltage	$T_A = -40^\circ C \sim +85^\circ C$	V_{CC}	1.0	--	6	V
Supply Current	$V_{CC} = V_{TH} + 1V$	I_{CC}	--	25	35	μA
Reset Threshold	MAX809/810L	V_{TH}	4.54	4.63	4.71	V
	MAX809/810M		4.29	4.38	4.46	
	MAX809/810J		3.92	4.00	4.08	
	MAX809/810T		3.02	3.08	3.15	
	MAX809/810S		2.87	2.93	3.00	
	MAX809/810R		2.57	2.63	2.69	
Reset Threshold Temperature Coefficient	$T_A = 0 \sim +85^\circ C$	V_{THT}	--	50	--	ppm/ $^\circ C$
Set-up Time	$V_{CC} = 0 \sim (V_{TH} - 100mV)$	T_{SET}	1	--	--	μs
V_{CC} to Reset Delay	$V_{CC} = V_{TH} \sim (V_{TH} - 100mV)$	T_{RD}	--	20	--	μs
Reset Active Timeout Period	$T_A = 0 \sim +85^\circ C$	T_{DELAY}	140	200	260	ms
RESET Output (MAX809) Voltage Low	$1.8V < V_{CC} < V_{TH(MAX)}$, $I_{SINK} = 1.2mA$	V_{OL}	--	--	0.3	V
	$1.2V < V_{CC} < 1.8V$, $I_{SINK} = 50\mu A$					
RESET Output (MAX809) Voltage High	$V_{CC} > V_{TH(MAX)}$, $I_{SOURCE} = 500\mu A$	V_{OH}	$0.8 V_{CC}$	--	--	V
(RESET) Output (MAX810) Voltage Low	$V_{CC} > V_{TH(MAX)}$, $I_{SINK} = 1.2mA$	V_{OL}	--	--	0.3	V

ELECTRICAL CHARACTERISTICS ($V_{CC} = 5V$, $T_A = 25^\circ C$ unless otherwise noted)

PARAMETER	CONDITIONS	SYMBOL	MIN	TYP	MAX	UNIT
(RESET) Output (MAX810) Voltage High	$1.8V < V_{CC} < V_{TH(MAX)}$, $I_{SOURCE} = 500\mu A$	V_{OH}	$0.8 V_{CC}$	--	--	V
	$1.2V < V_{CC} < 1.8V$, $I_{SOURCE} = 150\mu A$					
Hysteresis at V_{CC}	Input Voltage	V_{HVS}	--	40	--	mV

Note :

- $R_{\theta JA}$ is measured the PCB copper area of approximately $1in^2$ (Multi-layer). Needs to connect to V_{SS} pin.

BLOCK DIAGRAM

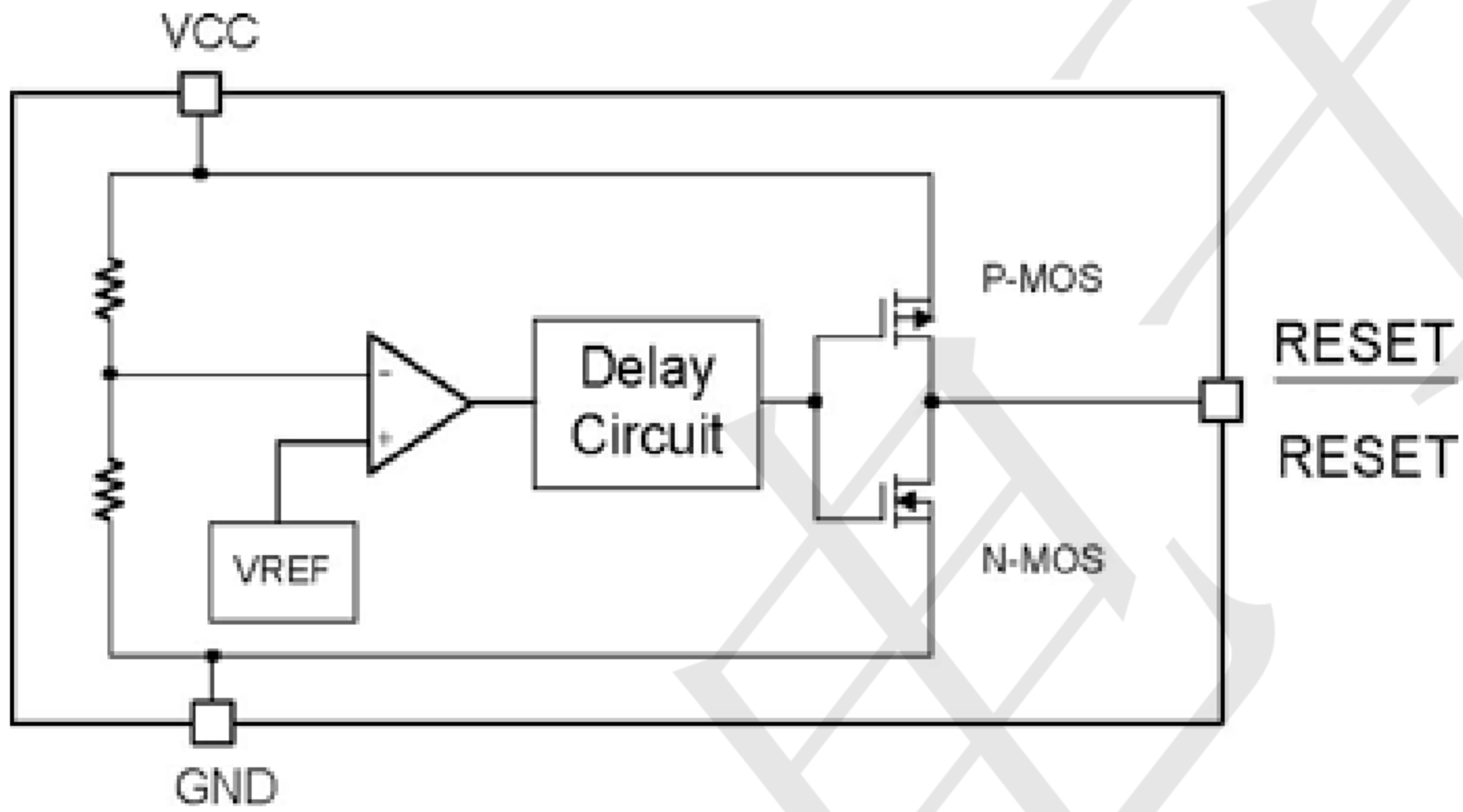

APPLICATION INFORMATION

Negative-Going V_{CC} transients in addition to issuing a reset to the μP during power-up, power-down, and brownout conditions, the MAX809/810 are relatively immune to short-duration negative-going V_{CC} transients (glitches).

The MAX809/810 does not generate a reset pulse. The graph was generated using a negative going pulse applied to V_{CC} , starting 0.5V above the actual reset threshold and ending below it by the magnitude indicated (reset comparator overdrive). The graph indicates the maximum pulse width a negative going V_{CC} transient can have without causing a reset pulse. As the magnitude of the transient increases (goes farther below the reset threshold), the maximum allowable pulse width decreases. Typically, a V_{CC} transient that goes 100mV below the reset threshold and lasts 20 μ S or less will not cause a reset pulse. A 0.1 μ F bypass capacitor mounted as close as possible to the V_{CC} pin provides additional transient immunity.

FUNCTION DESCRIPTION

A microprocessor's reset input starts the μP in a known state. The MAX809/810 assert reset to prevent code-execution errors during power-up, power-down, or brownout conditions. They assert a reset signal whenever the V_{CC} supply voltage declines below a preset threshold, keeping it asserted for at least 140ms after V_{CC} has risen above the reset threshold. The MAX809/810 have a push-pull output stage.

ENSURING A VALID RESET OUTPUT DOWN TO $V_{CC}=0$

RESET is guaranteed to be a logic low for $V_{CC} > 1.0V$. Once V_{CC} exceeds the reset threshold, an internal timer keeps RESET low for the reset timeout period; after this interval, RESET goes high. If a brownout condition occurs (V_{CC} dips below the reset threshold), RESET goes low. Any time V_{CC} goes below the reset threshold, the internal timer resets to zero, and RESET goes low. The internal timer starts after V_{CC} returns above the reset threshold, and RESET remains low for the reset timeout period. When V_{CC} falls below 1V, the MAX809/810 reset output no longer sinks current - it becomes an open circuit. Therefore, high impedance CMOS logic input connected to reset can drift to undetermined voltages. This present no problem in most applications since most μP and other circuitry is inoperative with V_{CC} below 1V. However, in applications where reset must be valid down to 0V, adding a pull down resistor to reset causes and stray leakage currents to flow to ground, holding reset low (Figure 2.) R1's value is not critical; 100K is large enough not to load reset and small enough to pull RESET to ground. For the MAX809/810 if reset is required to remain valid for $V_{CC} < 1V$.

BENEFITS OF HIGHLY ACCURATE RESET THRESHOLD

Most μP supervisor ICs has reset threshold voltages between 5% and 10% below the value of nominal supply voltages. This ensures a reset will not occur within 5% of the nominal supply, but will occur when the supply is 10% below nominal. When using ICs rated at only the nominal supply $\pm 5\%$, this leaves a zone of uncertainty where the supply is between 5% and 10% low, and where the reset many or may not be asserted.

TIMMING DIAGRAM

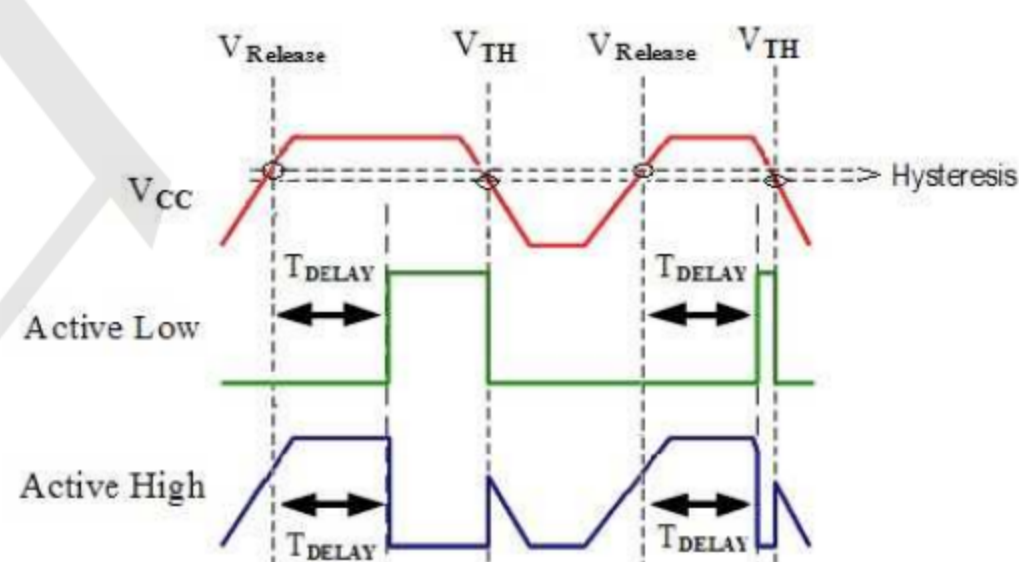

Package information

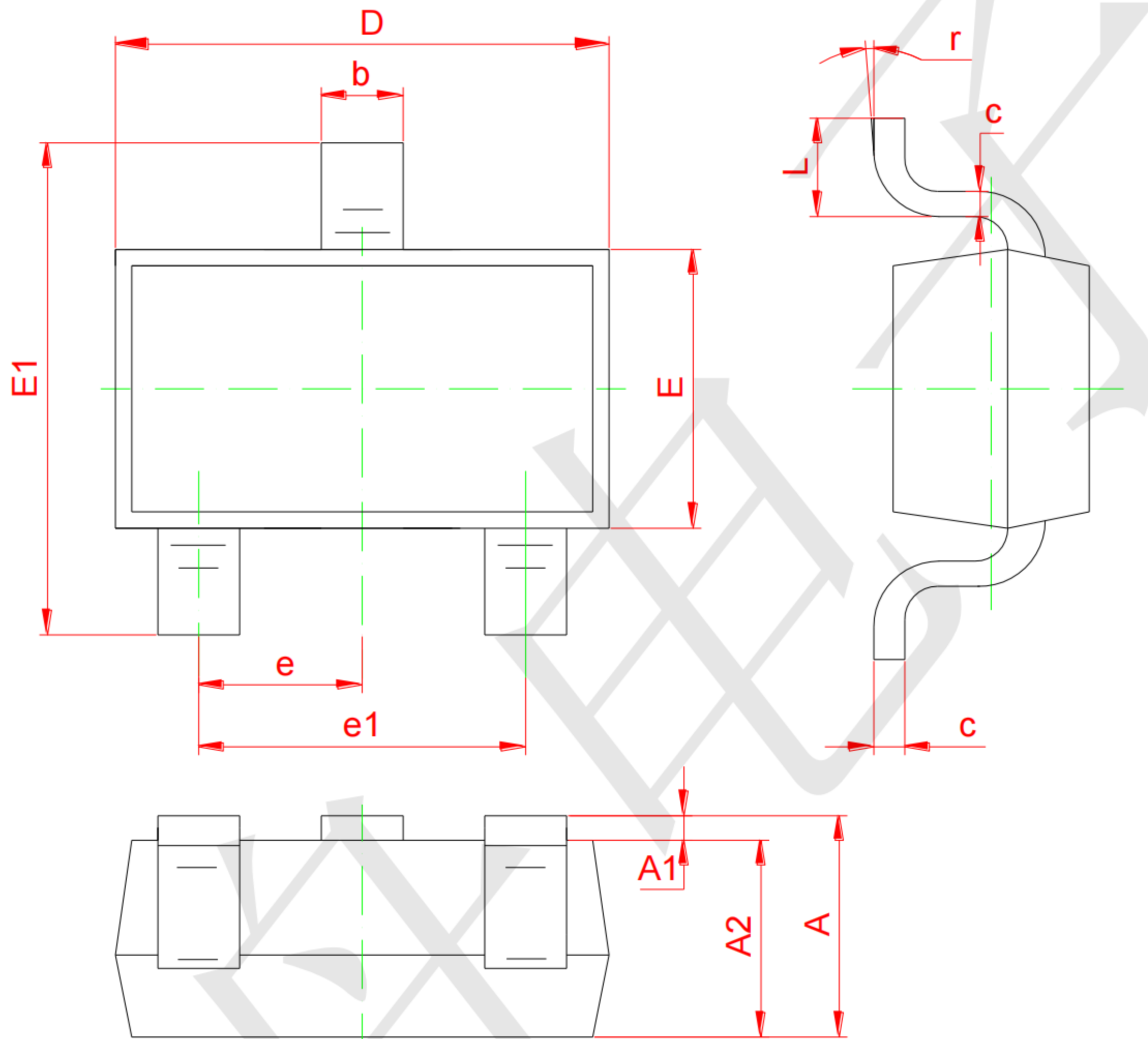

Symbol	Dimensions In Millimeters	
	Min	Max
A1	0.02	0.1
A2	1.0 Typical	
b	0.4 Typical	
c	0.1 Typical	
D	2.70	3.10
E	1.10	1.50
E1	2.20	2.60
e1	1.80	2.00
L	0.35	0.48