



FEATURES

- Powers up to 30 W (input) PDs
- DC/DC Control Optimized for Isolated Converters
- Supports High-efficiency Topologies
- Complete PoE Interface
- Enhanced Classification per IEEE 802.3at with Status Flag
- Adapter ORing Support
- Programmable Frequency with Synchronization
- Robust 85V, 0.4 Ω Hotswap MOSFET
- -40°C to 125°C Junction Temperature Range
- Industry Standard HTSSOP-20

APPLICATIONS

- IEEE 802.3at Compliant Devices
- Video and VoIP Telephones
- RFID Readers
- Multiband Access Points
- Security Cameras

DESCRIPTION

The WS3204 is a combined Power over Ethernet(PoE) powered device (PD) interface and current-mode dc/dc controller optimized specifically for isolated converters. The PoE interface supports the IEEE 802.3at standard.

The WS3204 supports a number of input voltage ORing options including highest voltage, external adapter preference, and PoE preference. These features allow the designer to determine which power source will carry the load under all conditions.

The PoE interface features the new extended hardware classification necessary for compatibility with high-power midspan power sourcing equipment (PSE) per IEEE 802.3at. The detection signature pin can also be used to force power from the PoE source off. Classification can be programmed to any of the defined types with a single resistor.

The dc/dc controller features two complementary gate drivers with programmable dead time. This simplifies design of active-clamp forward converts or optimized gate drive for highly-efficient flyback topologies. The second gate driver may be disabled if desired for single MOSFET topologies. The controller also features internal softstart, bootstrap startup source, current-mode compensation, and a 78% maximum duty cycle. A programmable and synchronizable oscillator allows design optimization for efficiency and eases use of the controller to upgrade existing power supply designs. Accurate programmable blank, with a default period, simplifies the usual current sense filter design trade-offs. The WS3204 has a 11 V converter startup.

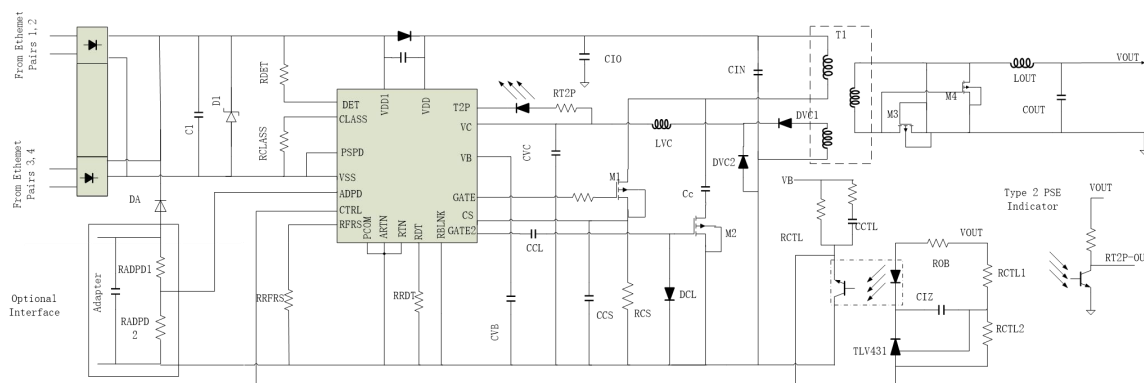

Figure 1. High Efficiency Converter Using WS3204

This integrated circuit can be damaged by ESD. WS3204 recommends that all integrated circuits be handled with appropriate precautions. Failure to observe proper handling and installation procedures can cause damage.

ESD damage can range from subtle performance degradation to complete device failure. Precision integrated circuits may be more susceptible to damage because very small parametric changes could cause the device not to meet its published specifications.

PRODUCT INFORMATION



High Power/High Efficiency PoE Interface and DC/DC Controller

	STATUS	DUTY CYCLE	POE UVLO ON / HYST.	CONVERTER UVLO ON / HYST.	FEATURE	PACKAGE	MARKING
WS3204	Active	0–78%	35/4.5	11 / 4	PSPD	HTSSOP-20	WS3204

ABSOLUTE MAXIMUM RATINGS^{(1) (2)}

Voltage with respect to V_{SS} unless otherwise noted.

	VALUE	UNIT
Input voltage range, ARTN ⁽²⁾ , PCOM ⁽²⁾ , DET, PSPD, RTN, V _{DD} , V _{DD1}	-0.3 to 85	V
Input voltage range CLASS ⁽³⁾	-0.3 to 6.5	V
Input voltage range [ADPD, RBLNK ⁽³⁾ , CTRL, RDT ⁽³⁾ , RFRS ⁽³⁾ , VB ⁽³⁾] to [ARTN, PCOM]	-0.3 to 6.5	V
Input voltage range CS to [ARTN, PCOM]	-0.3 to V _B	V
Input voltage range [ARTN, PCOM] to RTN	-2 to 2	V
Voltage range V _c , T2P, to [ARTN, PCOM]	-0.3 to 15	V
Voltage range GATE ⁽³⁾ , GATE2 ⁽³⁾ to [ARTN, PCOM]	-0.3 to V _c +0.3	V
Sinking current RTN	Internally limited	mA
Sourcing current V _B	Internally limited	mA
Average Sourcing or sinking current, GATE, GATE2	25	mArms
ESD rating, HBM	2	kV
ESD rating, CDM	500	V
ESD – system level (contact/air) at RJ-45 ⁽⁴⁾	8/15	kV
Operating junction temperature range, T _J	-40 to Internally limited	°C

(1) Stresses beyond those listed under absolute maximum ratings may cause permanent damage to the device. These are stress rating only and functional operation of the device at these or any other conditions beyond those indicated under recommended operating conditions is not implied. Exposure to absolute-maximum-rated conditions for extended periods may affect device reliability.

(2) ARTN and PCOM must be tied to RTN.

(3) Do not apply voltage to these pins

(4) ESD per EN61000-4-2. A power supply containing the WS3204 was subjected to the highest test levels in the standard. See the ESD section.



High Power/High Efficiency PoE Interface and DC/DC Controller

RECOMMENDED OPERATING CONDITIONS⁽¹⁾

Voltage with respect to V_{ss} (unless otherwise noted)

	MIN	NOM	MAX	UNIT
Input voltage range ARTN, PCOM, PSPD, RTN, VDD, VDD1	0		57	V
Input voltage range T2P, VC to [ARTN, PCOM]	0	12	15	V
Input voltage range ADPD, CTRL, RDT to [ARTN, PCOM]	0		VB	V
Input voltage range CS to [ARTN, PCOM]	0		2	V
Continuous RTN current (T _J ≤ 125°C) ⁽²⁾			825	mA
Sourcing current, VB	0	2.5	5	mA
VB capacitance	0.08			μF
RRBLNK	0		350	kΩ
Synchronization pulse width input (when used)	25			ns
Operating junction temperature range, T _J	-40		125	°C

- (1) ARTN and PCOM tied to RTN.
- (2) This is the minimum current-limit value. Viable systems will be designed for maximum currents below this value with reasonable margin. IEEE 802.3at permits 600mA continuous loading.

DISSIPATION RATINGS

PACKAGE	Ψ _{JT} °C/W ⁽¹⁾	θ _{JP} °C/W	θ _{JA} °C/W ⁽²⁾	θ _{JA} °C/W ⁽³⁾	MAXIMUM POWER RATING (W) ⁽⁴⁾
HTSSOP-20	0.607	1.4	32.6	73.8	1.2

- (1) T_J = T_{TOP} + (Ψ_{JT} × P_J)
- (2) This is a best case, natural convection number.
- (3) JEDEC method with high-k board (2 signal – 2 plane layers) and thermal pad not soldered (worst case).
- (4) Based on WST recommended layout and 85°C.

ELECTRICAL CHARACTERISTICS

Unless otherwise noted: CS=PCOM=ADPD=CTRL=RTN=ARTN, GATE and GATE2 float, R_{RFRS}=68 kΩ, R_{RRBLNK}=249 kΩ, RDT=V_B, PSPD=V_{SS}, T2P open, C_{VB}=C_{VC}=0.1μF, R_{DET}=24.9 kΩ, R_{CLASS} open, 0 V ≤ (V_{DD}, V_{DD1}) ≤ 57 V, 0 V ≤ V_C ≤ 12 V, -40°C ≤ T_J ≤ 125°C. Typical specifications are at 25°C.

CONTROLLER SECTION ONLY

[V_{SS} = RTN and V_{DD}=V_{DD1}] or [V_{SS}=RTN=V_{DD}], all voltages referred to [ARTN, PCOM].

PARAMETER		TEST CONDITIONS	MIN	TYP	MAX	UNIT
V_C						
V _{CUV}	UVLO	V _C rising	10.4	11	11.6	V
V _{CUVH}		Hysteresis ⁽¹⁾	3.7	4	4.3	V
Operating current		V _C =12V, CTRL=V _B , R _{RDT} =68.1kΩ	0.7	1.2	1.4	mA
t _{ST}	Bootstrap startup time, C _{VC} =22uF	V _{DD1} =13.2V, V _C (0)=0V	50	85	175	ms
		V _{DD1} =35V, V _C (0)=0V	27	45	92	
Startup current source I _{VC}		V _{DD1} =13.2V, V _C =8.6V	0.44	1.06	1.80	mA
		V _{DD1} =48V, V _C =0V	2.7	4.8	6.8	mA
V_B						
Voltage		6.5V ≤ V _C ≤ 12V, 0 ≤ I _{VB} ≤ 5mA	4.8	5.1	5.25	V
RFRS						
Switching frequency		CTRL=V _B , measure GATE, R _{RFRS} =68.1K	227	253	278	kHz
D _{MAX}	Duty cycle	CTRL=V _B , measure GATE	76	78	80	%
V _{SYNC}	Synchronization	Input threshold	2	2.2	2.4	V
CTRL						
V _{ZDC}	0% duty cycle threshold	V _{CTRL} ↓ until GATE stops	1.3	1.5	1.7	V
Softstart period		Interval from switching start to V _C MAX	1.9	3.9	6.2	ms
Input resistance			70	100	145	kΩ



High Power/High Efficiency PoE Interface and DC/DC Controller

RBLNK						
	Blanking delay	RBLNK=RTN	35	55	78	ns
	(in addition to t_1)	$R_{RBLNK}=49.9\text{ k}\Omega$	38	55	70	
RDT						
	Dead time See Figure 2 for t_{RDTx} definition	CTRL= V_B , $C_{GATE}=1\text{ nF}$, $C_{GATE2}=1\text{ nF}$, Measure GATE and GATE2				ns
t_{RDT1}		$R_{RDT}=24.9\text{ k}\Omega$, GATE2 \uparrow To GATE \uparrow	40	56	70	
t_{RDT2}		$R_{RDT}=24.9\text{ k}\Omega$, GATE \downarrow To GATE2 \downarrow	40	56	70	
t_{RDT1}		$R_{RDT}=75\text{ k}\Omega$, GATE2 \uparrow To GATE \uparrow	120	168	210	
t_{RDT2}		$R_{RDT}=75\text{ k}\Omega$, GATE \downarrow To GATE2 \downarrow	120	168	210	
CS						
V_{CSMAX}	Maximum threshold voltage	$V_{CTRL}=V_B$, V_{CS} rising until GATE duty cycles drops	0.5	0.55	0.6	V
t_1	Turnoff delay	$V_{CS}=0.65V$	24	40	70	ns
V_{SLOPE}	Internal slope compensation voltage	Peak voltage at maximum duty cycle, referenced to CS	120	155	185	mV
I_{SL_EX}	Peak slope compensation current	$V_{CTRL}=V_B$, I_{CS} at maximum duty cycle	30	42	54	μA
	Bias current (sourcing)	DC component of I_{CS}	1	2.5	4.3	μA
GATE						
	Source current	$V_{CTRL}=V_B$, $V_C=12V$, GATE high, pulsed measurement	0.37	0.6	0.95	A
	Sink current	$V_{CTRL}=V_B$, $V_C=12V$, GATE low, pulsed measurement	0.7	1	1.4	A
GATE2						
	Source current	$V_{CTRL}=V_B$, $V_C=12V$, GATE2 high, pulsed measurement, $R_{RDT}=24.9\text{ k}\Omega$	0.37	0.6	0.95	A
	Sink current	$V_{CTRL}=V_B$, $V_C=12V$, GATE2 low, pulsed measurement, $R_{RDT}=24.9\text{ k}\Omega$	0.7	1	1.4	A
ADPD/PSPD						
V_{ADPDEN}	ADPD threshold voltage	V_{ADPD} rising	1.43	1.5	1.57	V
V_{ADPDH}		Hysteresis ⁽¹⁾	0.29	0.31	0.33	
V_{PSPDEN}	PSPD threshold voltage	$V_{PSPD}-V_{VSS}$ rising, UVLO disable	1.45	1.55	1.65	V
V_{PSPDH}		Hysteresis ⁽¹⁾	0.29	0.31	0.33	
V_{PSPD2}		$V_{PSPD}-V_{VSS}$ rising, Class enable	7.4	8.3	9.2	V
V_{PSPD2H}		Hysteresis ⁽¹⁾	0.5	0.6	0.7	
	ADPD leakage current (source or sink)	$V_C=12V$, $V_{ADPD}=V_B$			1	μA
I_{PSPD}	PSPD sink current	$V_{PSPD}-V_{VSS}=1.5V$	2.5	5	7.5	μA
THERMAL SHUTDOWN						
	Turnoff temperature	T_J rising	135	145	155	$^{\circ}\text{C}$
	Hysteresis ⁽²⁾			20		$^{\circ}\text{C}$

(1) The hysteresis tolerance tracks the rising threshold for a given device.

(2) These parameters are provided for reference only, and do not constitute part of WST's published specifications for purposes of WST's product warranty.



High Power/High Efficiency PoE Interface and DC/DC Controller

ELECTRICAL CHARACTERISTICS – PoE AND CONTROL

[V_{DD}=V_{DD1}] or [V_{DD1}=RTN], V_C = RTN, P_{COM}=RTN=ARTN, all voltages referred to V_{SS} unless otherwise noted

PARAMETER		TEST CONDITIONS	MIN	TYP	MAX	UNIT	
DETECTION (DET)		V _{DD} =V _{DD1} =RTN=V _{SUPPLY} positive					
Detection current		Measure I _{SUPPLY}					
		V _{DD} =1.6V	62	64.3	66.5	uA	
		V _{DD} =10V	399	406	414		
Detection bias current		V _{DD} =10V, float DET, measure I _{SUPPLY}		5.6	10	uA	
		Note: not during Mark state					
V _{PD_DIS}	Hotswap disable threshold		3	4	5	V	
DET leakage current		V _{DET} =V _{DD} =57V, float VDD1 and RTN, measure I _{DET}		0.1	5	uA	
CLASSIFICATION (CLASS)		(V _{DD} = V _{DD1} = RTN = V _{SUPPLY} positive)					
I _{CLASS}		13V≤V _{DD} ≤21V, measure I _{SUPPLY}				mA	
		R _{CLASS} =1270Ω	1.8	2.1	2.4		
		Classification current,	R _{CLASS} =243Ω	9.9	10.4		10.9
		applies to both cycles	R _{CLASS} =137Ω	17.6	18.5		19.4
			R _{CLASS} =90.9Ω	26.5	27.7		29.3
Classification mark resistance		5.6V≤V _{DD} ≤9.4V	7.5	9.7	12	kΩ	
V _{CL_ON}	Classification regulator lower threshold	Regulator turns on, V _{DD} rising	11.2	11.9	12.6	V	
V _{CL_H}		Hysteresis ⁽¹⁾	1.55	1.65	1.75		
V _{CU_OFF}	Classification regulator upper threshold	Regulator turns off, V _{DD} rising	21	22	23	V	
V _{CU_H}		Hysteresis ⁽¹⁾	0.5	0.75	1.0		
V _{MSR}	Mark state reset	V _{DD} falling	3	4	5	V	
Leakage current		V _{DD} =57V, V _{CLASS} =0V, DET=V _{SS} , measure I _{CLASS}			1	uA	
PASS DEVICE (RTN)		V _{DD1} =RTN					
On resistance			0.25	0.35	0.65	Ω	
Current limit		V _{RTN} =1.5V, V _{DD} =48V, pulsed measurement	850	970	1200	mA	
Inrush limit		V _{RTN} =2V, V _{DD} :0V->48V, pulsed measurement	100	140	180	mA	
Fold-back voltage threshold		V _{DD} rising	11	12.3	13.6	V	
UVLO							
V _{UVLO_R}	UVLO threshold	V _{DD} rising	33.9	35	36.1	V	
V _{UVLO_H}		Hysteresis ⁽¹⁾	4.4	4.55	4.76		
T2P							
On characteristic		Perform classification algorithm, V _{T2P-RTN} =1V, CTRL=RTN	2			mA	
Leakage current		V _{T2P} =12V, CTRL=V _B			10	uA	
t _{T2P}	delay	From start of switching to T2P active	5	9	15	ms	
THERMAL SHUTDOWN							
Turnoff temperature		T _J rising	135	145	155	°C	
Hysteresis ⁽²⁾				20		°C	

(1) The hysteresis tolerance tracks the rising threshold for a given device.

(2) These parameters are provided for reference only, and do not constitute part of WST's published specifications for purposes of WST's product warranty.

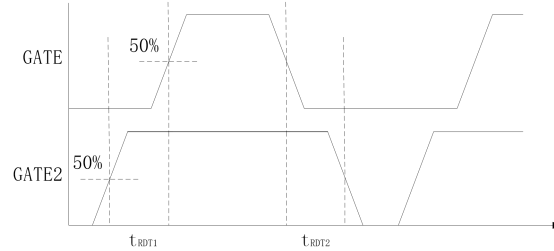
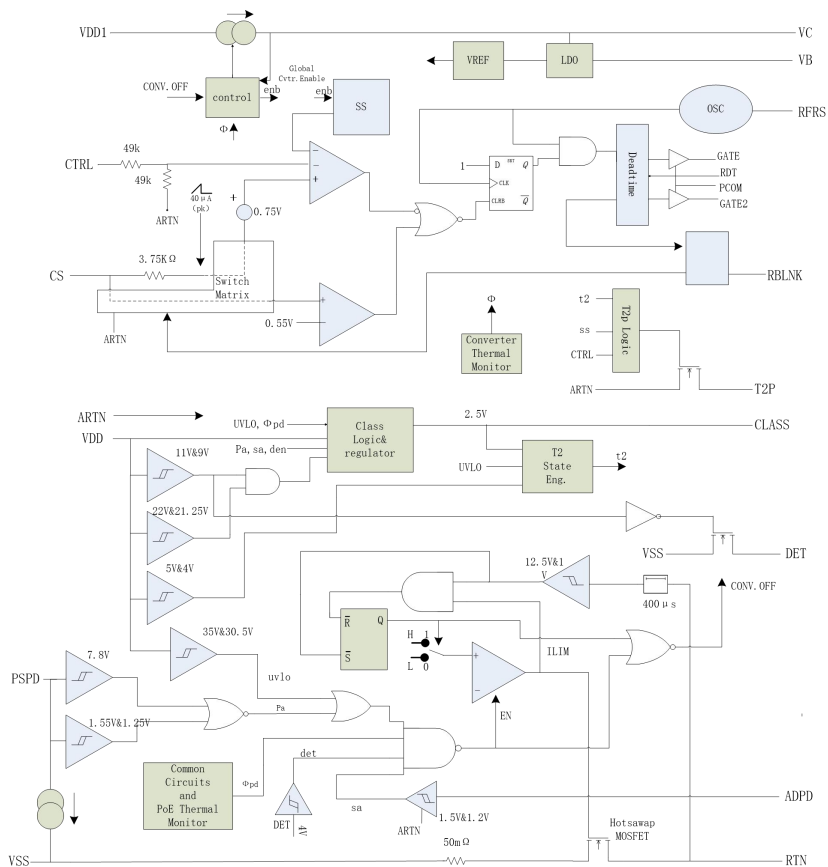

Figure 2. GATE and GATE2 Timing and Phasing

DEVICE INFORMATION

FUNCTIONAL BLOCK DIAGRAM





High Power/High Efficiency PoE Interface and DC/DC Controller

(TOP VIEW)

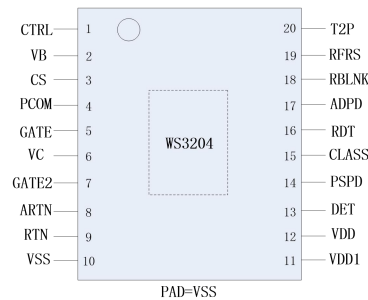

PIN FUNCTIONS

NAME	NUM	TYPE	DESCRIPTION
CTRL	1	I	The control loop input to the PWM (pulse width modulator), typically driven by output regulation feedback (e.g. optocoupler). Use V_B as a pullup for CTRL.
VB	2	O	5.1 V bias rail for dc/dc control circuits and the feedback optocoupler. Typically bypass with a 0.1 μ F to ARTN.
CS	3	I/O	DC/DC converter switching MOSFET current sense input. See R_{CS} in Figure 1.
PCOM	4		Gate driver return, connect to ARTN and RTN.
GATE	5	O	Gate drive output for the main dc/dc converter switching MOSFET
VC	6	I/O	DC/DC converter bias voltage. Connect a 0.47 μ F (minimum) ceramic capacitor to ARTN at the pin, and a larger capacitor to power startup.
GATE2	7	O	Gate drive output for a second dc/dc converter switching MOSFET (see Figure 1).
ARTN	8		ARTN is the dc/dc converter analog return. Tie to RTN and PCOM on the circuit board.
RTN	9		RTN is the output of the PoE hotswap MOSFET.
VSS	10		Connect to the negative power rail derived from the PoE source.
VDD1	11	I	Source of dc/dc converter startup current. Connect to VDD for many applications.
VDD	12	I	Connect to the positive PoE input power rail. VDD powers the PoE interface circuits. Bypass with a 0.1 μ F capacitor and protect with a TVS.
DET	13	I/O	Connect a 24.9 k Ω resistor from DET to VDD to provide the PoE detection signature. Pulling this pin to VSS during powered operation causes the internal hotswap MOSFET to turn off.
PSPD	14	I	Raising V_{PSPD} -VSS above 1.55 V enables the hotswap MOSFET and activates T2P. Connecting PSPD to VDD enables classification when ADPD is active. Tie PSPD to VSS or float when not used.
CLASS	15	I	Connect a resistor from CLASS to VSS to program classification current. 2.5 V is applied to the program resistor during classification to set class current.
RDT	16	I	Connect a resistor from RDT to ARTN to set the GATE to GATE2 dead time. Tie RDT to VB to disable GATE2 operation.
ADPD	17	I	Raising V_{ADPD} - V_{ARTN} above 1.5 V disables the internal hotswap switch, turns class off, and forces T2P active. This forces power to come from a external VDD1-RTN adapter. Tie ADPD to ARTN when not used.
RBLNK	18	I	Connect to ARTN to utilize the internally set current-sense blanking period, or connect a resistor from RBLNK to ARTN to program a more accurate period.
RFRS	19	I	Connect a resistor from RFRS to ARTN to program the converter switching frequency. RFRS may be used to synchronize the converter to an external timing source.
T2P	20	O	Active low output that indicates a PSE has performed the IEEE 802.3at type 2 hardware classification, PSPD is active, or ADPD is active.
Pad	-		Connect to VSS.



PIN DESCRIPTION

Refer to Figure 1 for component reference designators (RCS for example), and the Electrical Characteristics table for values denoted by reference (VCSMAX for example). Electrical Characteristic values take precedence over any numerical values used in the following sections.

ADPD

ADPD forces power to come from an external adapter connected from VDD1 to RTN by opening the hotswap switch, disabling the CLASS output (see PSPD pin description), and enabling the T2P output. A resistor divider is recommended on ADPD when it is connected to an external adapter. The divider provides ESD protection, leakage discharge for the adapter ORing diode, and input voltage qualification. Voltage qualification assures the adapter output voltage is high enough that it can support the PD before the PoE current is cut off. Select the ADPD divider resistors per Equation 1 where VADPTR-ON is the desired adapter voltage that enables the ADPD function as adapter voltage rises.

$$R_{ADPD1} = R_{ADPD2} \times (V_{ADPTR_ON} - V_{ADPDEN}) / V_{ADPDEN}$$

$$V_{ADPTR_OFF} = \frac{R_{ADPD1} + R_{ADPD2}}{R_{ADPD2}} \times (V_{ADPDEN} - V_{ADPDH}) \tag{1}$$

Place the ADPD pull-down resistor adjacent to the ADPD pin. ADPD should be tied to ARTN when not used.

RBLNK

Blanking provides an interval between GATE going high and the current-control comparators on CS actively monitoring the input. This delay allows the normal turn-on current transient (spike) to subside before the comparators are active, preventing undesired short duty cycles and premature current limiting. Connect RBLNK to ARTN to obtain the internally set blanking period and the programming resistor is defined by Equation 2.

$$R_{RBLNK}(k \Omega) = t_{RBLNK}(ns) \tag{2}$$

Place the resistor adjacent to the RBLNK pin when it is used.

CLASS

A resistor from CLASS to Vss programs the classification current per the IEEE standard. The PD power ranges and corresponding resistor values are listed in Table 1. The power assigned should correspond to the maximum average power drawn by the PD during operation. High-power PSEs may perform two classification cycles if Class 4 is presented on the first cycle. The WS3204 presents the same (resistor programmed) class each cycle per the standard.

Table 1. Class Resistor Selection

CLASS	POWER AT PD		RESISTOR (Ω)	NOTES
	MINIMUM	MAXIMUM		
	(W)	(W)		
0	0.44	12.95	1270	Minimum may be reduced by pulsed loading. Serves as a catch-all default class.
1	0.44	3.84	243	
2	3.84	6.49	137	
3	6.49	12.95	90.9	
4	12.95	25.5	63.4	Not allowed prior to IEEE 802.3at. Use to indicate a Type 2 PD (high power) device per IEEE 802.3at.

**CS**

The CS (current sense) input for the dc/dc converter should be connected to the high side of the switching MOSFET's current sense resistor (R_{CS}). The current-limit threshold, V_{CSMAX} , defines the voltage on CS above which the GATE ON time will be terminated regardless of the voltage on CTRL.

The WS3204 provides internal slope compensation (150 mV, V_{SLOPE}), an output current for additional slope compensation, a peak current limiter, and an off-time pull-down to this pin.

Routing between the current-sense resistor and the CS pin should be short to minimize cross-talk from noisy traces such as the gate drive signal.

CTRL

CTRL (control) is the voltage-control loop input to the PWM (pulse width modulator). Pulling V_{CTRL} below V_{ZDC} causes GATE to stop switching. Increasing V_{CTRL} above V_{ZDC} (zero duty cycle voltage) raises the switching MOSFET programmed peak current. The maximum (peak) current is requested at approximately $V_{ZDC} + (2 \times V_{CSMAX})$. The ac gain from CTRL to the PWM comparator is 0.5. The internal divider from CTRL to ARTN is approximately 100 k Ω .

Use V_B as a pull up source for CTRL.

DET

DET (detection and enable) is a multifunction pin for PoE detection and inhibiting operation from PoE power. Connect a 24.9 k Ω resistor from DET to V_{DD} to provide the PoE detection signature. DET goes to a high-impedance state when $V_{VDD-VSS}$ is outside of the detection range. Pulling DET to V_{SS} during powered operation causes the internal hotswap MOSFET and class regulator to turn off, while the reduced detection resistance prevents the PD from properly re-detecting.

RDT

Dead-time programming sets the delay between GATE and GATE2 to prevent overlap of MOSFET ON times as shown in [Figure 2](#). GATE2 turns the second MOSFET off when it transitions high. Both MOSFETs should be off between GATE2 going high to GATE going high, and GATE going low to GATE2 going low. The maximum GATE ON time is reduced by the programmed dead-time period. The dead time period is specified with 1 nF of capacitance on GATE and GATE2. Different loading on these pins will change the effective dead time. A resistor connected from RDT to ARTN sets the delay between GATE and GATE2 per [Equation 3](#).

$$R_{RDT}(\text{k}\Omega) = \frac{t_{RDT}(\text{ns})}{2} \quad (3)$$

Connect RDT to V_B to set the dead time to 0 and turn GATE2 off.

RFRS

Connect a resistor from RFRS (frequency and synchronization) to ARTN to program the converter switching frequency. Select the resistor per the following relationship.

$$R_{RFRS}(\text{k}\Omega) = \frac{17250}{f_{SW}(\text{kHz})} \quad (4)$$

The converter may be synchronized to a frequency above its maximum free-running frequency by applying short ac-coupled pulses into the RFRS pin per [Figure 30](#).

The RFRS pin is high impedance. Keep the connections short and apart from potential noise sources. Special care should be taken to avoid crosstalk when synchronizing circuits are used.

GATE

Gate drive output for the dc/dc converter's main switching MOSFET. GATE's phase turns the main switch on when it transitions high, and off when it transitions low. GATE is held low when the converter is disabled.

GATE2



High Power/High Efficiency PoE Interface and DC/DC Controller

GATE2 is the second gate drive output for the dc/dc converter. GATE2's phase turns the second switch off when it transitions high, and on when it transitions low. This drives active-clamp PMOS devices per [Figure 1](#), and driven flyback synchronous rectifiers per [Figure 28](#). See the RDT Pin Description for GATE to GATE2 timing. Connecting RDT to V_B disables GATE2 in a high-impedance condition. GATE2 is low when the converter is disabled.

PSPD

PSPD is a multifunction pin that has two voltage thresholds, PSPD1 and PSPD2.

PSPD1 permits power to come from an external low voltage adapter, e.g., 24 V, connected from V_{DD} to V_{SS} by over-riding the normal hotswap UVLO. Voltage on PSPD above 1.55 V (V_{PSPDEN}) enables the hotswap MOSFET, inhibits class current, and enables T2P. A resistor divider per [Figure 35](#) provides ESD protection, leakage discharge for the adapter ORing diode, reverse adapter protection, and input voltage qualification. Voltage qualification assures the adapter output voltage is high enough that it can support the PD before it begins to draw current.

$$R_{PSPD1} = \left(\frac{V_{ADPTR_ON} - V_{PSPDEN}}{\frac{V_{PSPDEN} - V_{PSPDH}}{R_{PSPD2}} - I_{PSPD}} \right)$$

$$V_{ADPTR_OFF} = (V_{PSPDEN} - V_{PSPDH}) + \left[R_{PSPD1} \times \left(\frac{V_{PSPDEN} - V_{PSPDH}}{R_{PSPD2}} - I_{PSPD} \right) \right] \quad (5)$$

PSPD2 enables normal class regulator operation when V_{PSPD} is above 8.3 V to permit type 2 classification when ADPD is used in conjunction with diode D_{VDD} (see [Figure 34](#)). Tie PSPD to V_{DD} when PSPD2 operation is desired.

The PSPD pin has a 5 μ A internal pull-down current.

Locate the PSPD pull-down resistor adjacent to the pin when used.

PSPD may be tied to V_{SS} or left open when not used.

RTN, ARTN, PCOM

RTN is internally connected to the drain of the PoE hotswap MOSFET, while ARTN is the quiet analog reference for the dc/dc controller return. PCOM serves as the return path for the gate drivers and should be tied to ARTN on the circuit board. The ARTN / PCOM / RTN net should be treated as a local reference plane (ground plane) for the dc/dc control and converter primary. RTN and (ARTN/PCOM) may be separated by several volts for special applications.

T2P

T2P is an active low output that indicates [($V_{ADPD} > 1.5$ V) OR (1.55 V $\leq V_{PSPD} \leq 8.3$ V) OR (type 2 hardware classification observed)]. T2P is valid after both a delay of t_{T2P} from the start of converter switching, and [$V_{CTRL} \leq (V_B - 1$ V)]. Once T2P is valid, V_{CTRL} will not effect it. T2P will become invalid if the converter goes back into softstart, over-temperature, or is held off by the PD during C_{IN} recharge (inrush). T2P is referenced to ARTN and is intended to drive the diode side of an optocoupler. T2P should be left open or tied to ARTN if not used.

VB

V_B is an internal 5.1V regulated dc/dc controller supply rail that is typically bypassed by a 0.1 μ F capacitor to ARTN. V_B should be used to bias the feedback optocoupler.

VC

V_C is the bias supply for the dc/dc controller. The MOSFET gate drivers run directly from V_C . V_B is regulated down from V_C , and is the bias voltage for the rest of the converter control. A startup current source from V_{DD1} to V_C is controlled by a comparator with hysteresis to implement the converter bootstrap startup. V_C must be connected to a bias source, such as a converter auxiliary output, during normal operation. A minimum 0.47 μ F capacitor, located adjacent to the V_C pin, should be connected from V_C to PCOM to bypass the gate driver. A larger total capacitance is required for startup to provide control power between the time the converter starts switching and the availability of the converter auxiliary output voltage.

VDD

V_{DD} is the positive input power rail that is derived from the PoE source (PSE). V_{DD} should be bypassed to V_{SS} with a 0.1 μ F capacitor as required by the IEEE standard. A transient suppressor diode (TVS), a special type of Zener diode, such



High Power/High Efficiency PoE Interface and DC/DC Controller

as SMAJ58A should be connected from V_{DD} to V_{SS} to protect against over-voltage transients.

VDD1

V_{DD1} is the dc/dc converter startup supply. Connect to V_{DD} for many applications. V_{DD1} may be isolated by a diode from V_{DD} to support PoE priority operation.

VSS

V_{SS} is the PoE input-power return side. It is the reference for the PoE interface circuits, and has a current-limited hotswap switch that connects it to RTN. V_{SS} is clamped to a diode drop above RTN by the hotswap switch.

A local V_{SS} reference plane should be used to connect the input bypass capacitor, TVS, R_{CLASS} , and the Thermal Pad. This plane becomes the main heatsink for the WS3204.

V_{SS} is internally connected to the Thermal PAD.

THERMAL PAD

The Thermal pad is internally connected to V_{SS} . It should be tied to a large V_{SS} copper area on the PCB to provide a low resistance thermal path to the circuit board. It is recommended that a clearance of 0.025" be maintained between V_{SS} , RTN, and various control signals to high-voltage signals such as V_{DD} and V_{DD1} .

TYPICAL CHARACTERISTICS

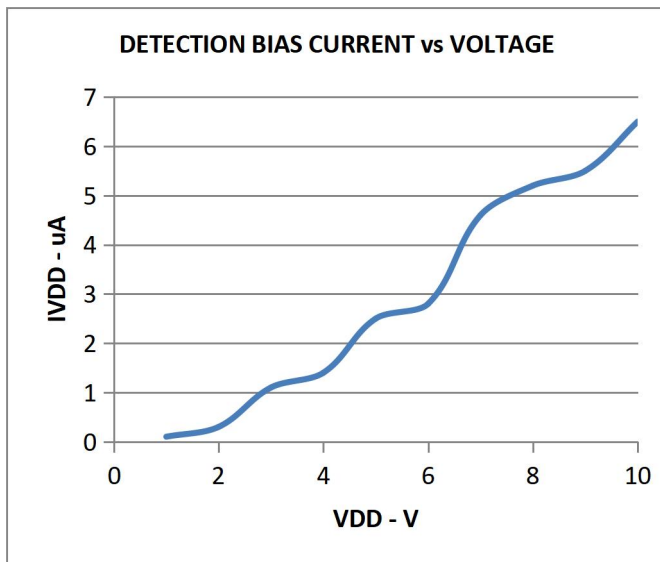

Figure 3.

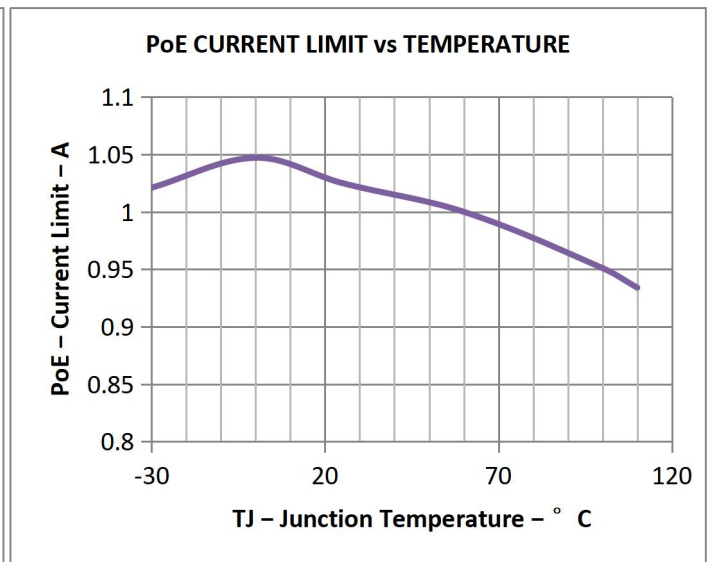

Figure 4.



TYPICAL CHARACTERISTICS (continued)

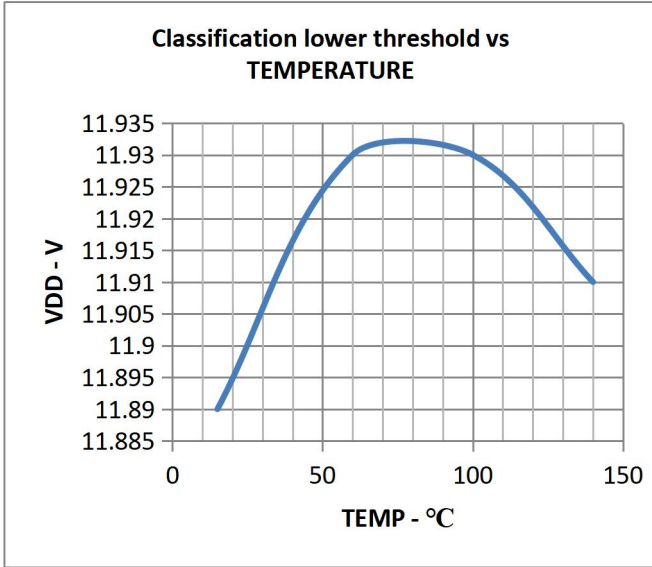

Figure 5.

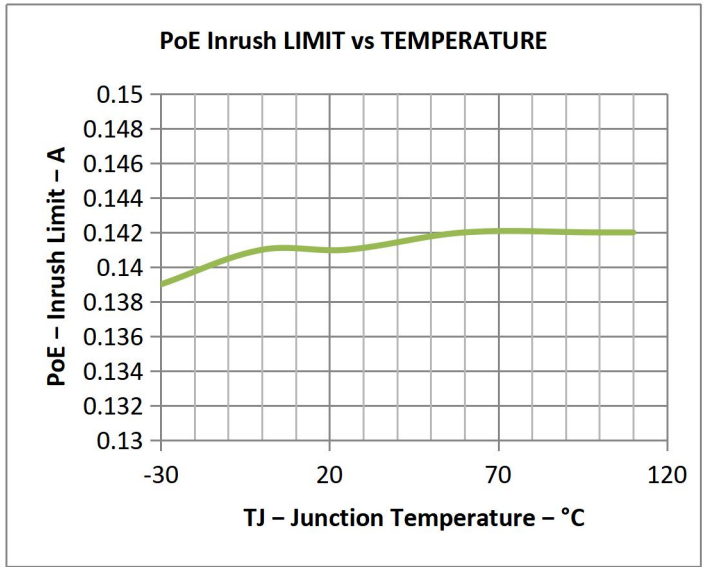

Figure 6.

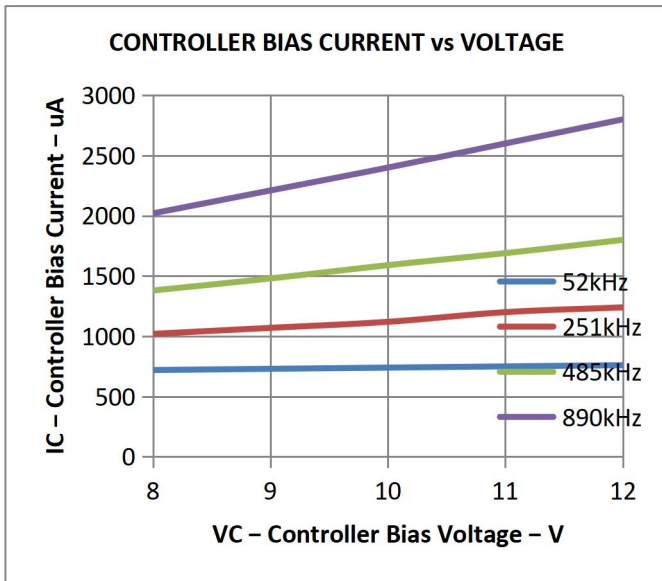

Figure 7.

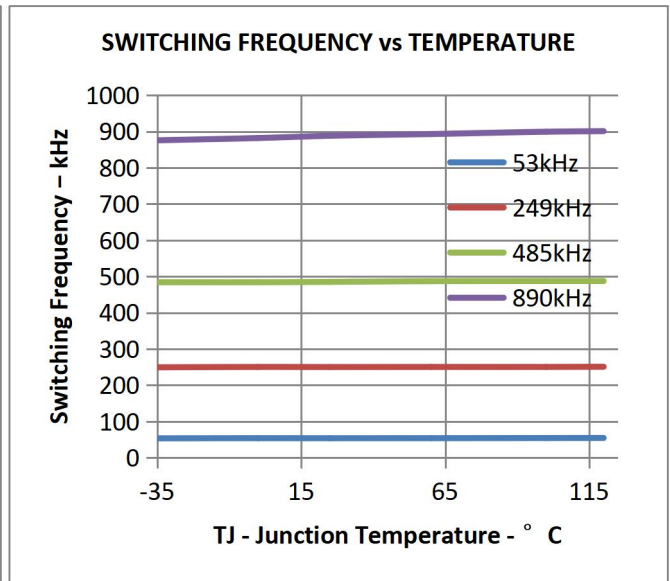

Figure 8.

TYPICAL CHARACTERISTICS (continued)

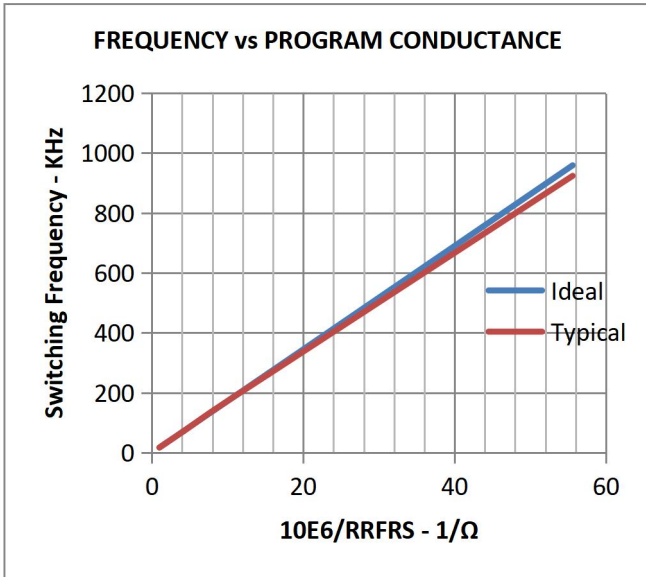

Figure 9.

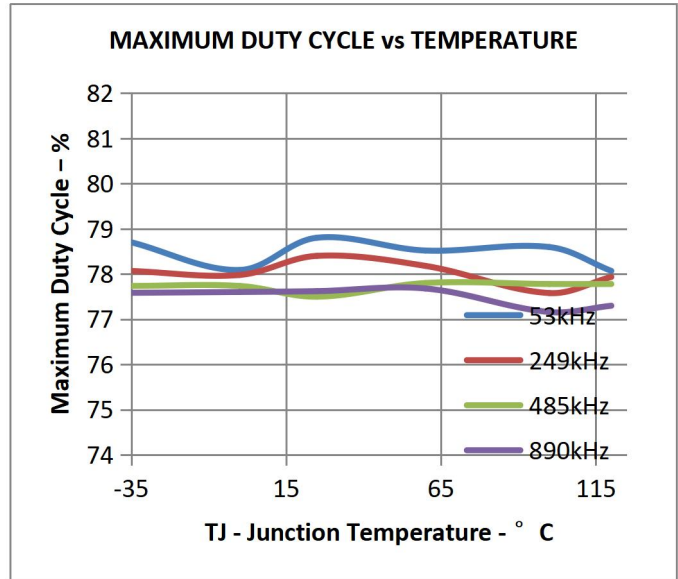

Figure 10.

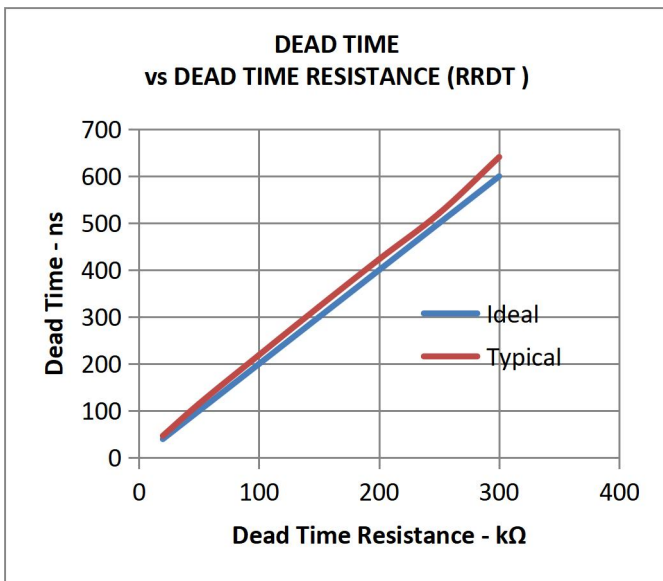

Figure 11.

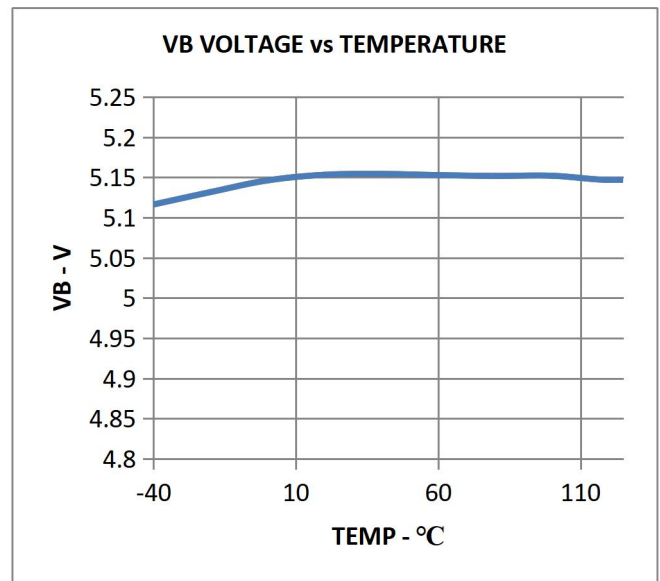

Figure 12

DETAILED DESCRIPTION

PoE OVERVIEW

China·Nanjing City ·No.166 Middle Zhengfang Road
Email: support@gbdz.net

Tel: +86-25-68005828 Fax: +86-25-68005835
<http://www.gbdz.net>



High Power/High Efficiency PoE Interface and DC/DC Controller

The following text is intended as an aid in understanding the operation of the WS3204 but not as a substitute for the IEEE 802.3at standard. The IEEE 802.3at standard is an update to IEEE 802.3-2008 clause 33 (PoE), adding high-power options and enhanced classification. Generally speaking, a device compliant to IEEE 802.3-2008 is referred to as a type 1 device, and devices with high power and enhanced classification will be referred to as type 2 devices. Standards change and should always be referenced when making design decisions.

The IEEE 802.3at standard defines a method of safely powering a PD (powered device) over a cable by power sourcing equipment (PSE), and then removing power if a PD is disconnected. The process proceeds through an idle state and three operational states of detection, classification, and operation. The PSE leaves the cable unpowered (idle state) while it periodically looks to see if something has been plugged in; this is referred to as detection. The low power levels used during detection are unlikely to damage devices not designed for PoE. If a valid PD signature is present, the PSE may inquire how much power the PD requires; this is referred to as classification. The PSE may then power the PD if it has adequate capacity.

Type 2 PSEs are required to do type 1 hardware classification plus a (new) data-layer classification, or an enhanced type 2 hardware classification. Type 1 PSEs are not required to do hardware or data link layer (DLL) classification. A type 2 PD must do type 2 hardware classification as well as DLL classification. The PD may return the default, 13W current-encoded class, or one of four other choices. DLL classification occurs after power-on and the ethernet data link has been established.

Once started, the PD must present the maintain power signature (MPS) to assure the PSE that it is still present. The PSE monitors its output for a valid MPS, and turns the port off if it loses the MPS. Loss of the MPS returns the PSE to the idle state. Figure 21 shows the operational states as a function of PD input voltage. The upper half is for IEEE 802.3-2008, and the lower half shows specific differences for IEEE 802.3at. The dashed lines in the lower half indicate these are the same (e.g., Detect and Class) for both.

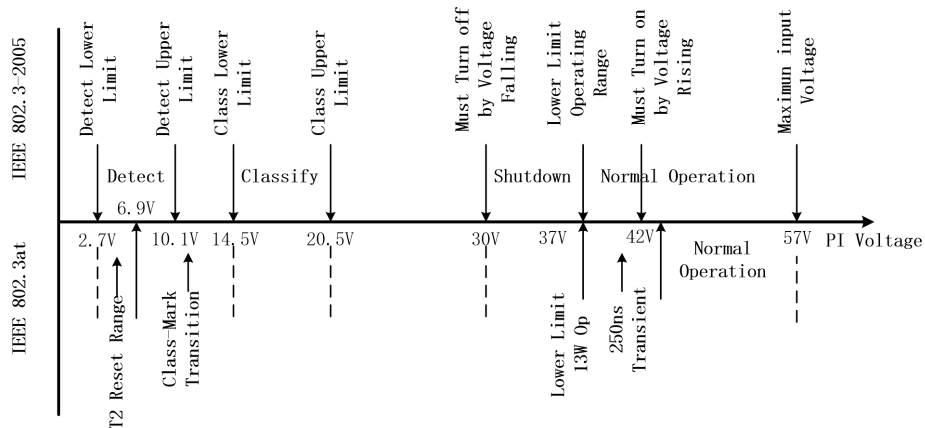

Figure 21. Operational States for PD

The PD input, typically an RJ-45 eight-lead connector, is referred to as the power interface (PI). PD input requirements differ from PSE output requirements to account for voltage drops and operating margin. The standard allots the maximum loss to the cable regardless of the actual installation to simplify implementation. IEEE 802.3-2008 was designed to run over infrastructure including ISO/IEC 11801 class C (CAT3 per TIA/EIA-568) that may have had AWG 26 conductors. IEEE 802.3at type 2 cabling power loss allotments and voltage drops have been adjusted for 12.5 Ω power loops per ISO/IEC11801 class D (CAT5 or higher per TIA/EIA-568, typically AWG #24 conductors). Table 2 shows key operational limits broken out for the two revisions of the standard.



Table 2. Comparison of Operational Limits

STANDARD	POWER LOOP RESISTANCE (max)	PSE OUTPUT POWER (min)	PSE STATIC OUTPUT VOLTAGE (min)	PD INPUT POWER (max)	STATIC PD INPUT VOLTAGE	
					POWER ≤ 12.95 W	POWER > 12.95 W
IEEE 802.3-2008 802.3at (Type 1)	20 Ω	15.4 W	44 V	12.95 W	37 V–57 V	N/A
802.3at (Type 2)	12.5 Ω	36 W	50 V	25.5 W	37 V–57 V	42.5 V–57 V

The PSE can apply voltage either between the RX and TX pairs (pins 1 - 2 and 3 - 6 for 10baseT or 100baseT), or between the two spare pairs (4 - 5 and 7 - 8). Power application to the same pin combinations in 1000baseT systems is recognized in IEEE 802.3at. 1000baseT systems can handle data on all pairs, eliminating the spare pair terminology. The PSE may only apply voltage to one set of pairs at a time. The PD uses input diode bridges to accept power from any of the possible PSE configurations. The voltage drops associated with the input bridges create a difference between the standard limits at the PI and the WS3204 specifications.

A compliant type 2 PD has power management requirements not present with a type 1 PD. These requirements include the following:

1. Must interpret type 2 hardware classification
2. Must present hardware class 4
3. Must implement DLL negotiation
4. Must behave like a type 1 PD during inrush and startup
5. Must not draw more than 13W for 80ms after PSE applies operating voltage (power-up)
6. Must not draw more than 13W if it has not received a type 2 hardware classification or received permission through DLL
7. Must meet various operating and transient templates
8. Optionally monitor for the presence or absence of an adapter (assume high power).

As a result of these requirements, the PD must be able to dynamically control its loading, and monitor T2P for changes. In cases where the design needs to know specifically if an adapter is plugged in and operational, the adapter should be individually monitored, typically with an optocoupler.

Threshold Voltages

The WS3204 has a number of internal comparators with hysteresis for stable switching between the various states. Figure 22 relates the parameters in the Electrical Characteristics section to the PoE states. The mode labeled idle between classification and operation implies that the DET, CLASS, and RTN pins are all high impedance. The state labeled Mark, which is drawn in dashed lines, is part of the new type 2 hardware class state machine.

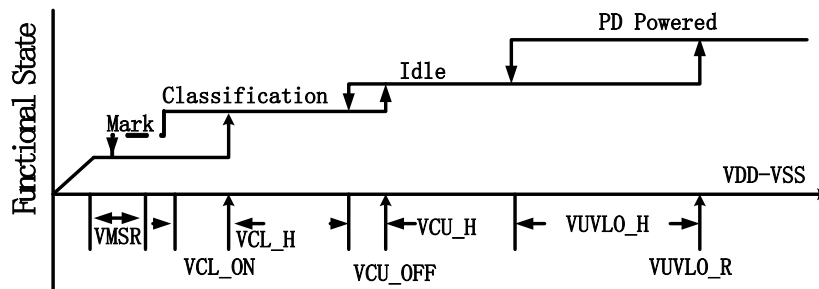

Figure 22. Threshold Voltages

PoE Startup Sequence



High Power/High Efficiency PoE Interface and DC/DC Controller

The waveforms of Figure 23 demonstrate detection, classification, and startup from a PSE with type 2 hardware classification. The key waveforms shown are $V_{DD}-V_{SS}$, $V_{RTN}-V_{SS}$, and I_{PI} . IEEE 802.3at requires a minimum of two detection levels, two class and mark cycles, and startup from the second mark event. V_{RTN} to V_{SS} falls as the WS3204 charges C_{IN} following application of full voltage. Subsequently, the converter starts up, drawing current as seen in the I_{PI} waveform.

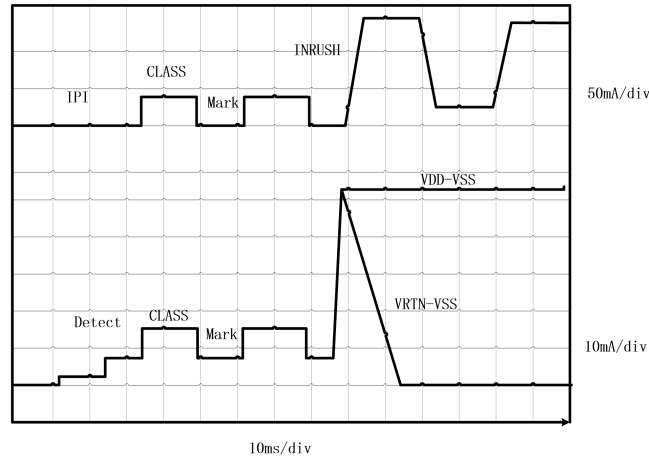

Figure 23. Startup

Detection

The WS3204 drives DET to V_{SS} whenever $V_{DD}-V_{SS}$ is below the lower classification threshold. When the input voltage rises above V_{CL-ON} , the DET pin goes to an open-drain condition to conserve power. While in detection, RTN is high impedance, and almost all the internal circuits are disabled. An R_{DET} of 24.9 k Ω (1%), presents the correct signature. It may be a small, low-power resistor since it only sees a stress of about 5 mW. A valid PD detection signature is an incremental resistance ($\Delta V / \Delta I$) between 23.75 k Ω and 26.25 k Ω at the PI.

The detection resistance seen by the PSE at the PI is the result of the input bridge resistance in series with the parallel combination of R_{DET} and internal V_{DD} loading. The input diode bridge's incremental resistance may be hundreds of ohms at the very low currents drawn when 2.7 V is applied to the PI. The input bridge resistance is partially cancelled by the WS3204's effective resistance during detection.

The type 2 hardware classification protocol of IEEE 802.3at specifies that a type 2 PSE drops its output voltage into the detection range during the classification sequence. The PD is required to have an incorrect detection signature in this condition, which is referred to as the mark event (see Figure 23). After the first mark event, the WS3204 will present a signature less than 12 k Ω until it has experienced a $V_{DD}-V_{SS}$ voltage below the mark reset (V_{MSR}). This is explained more fully under Hardware Classification.

Hardware Classification

Hardware classification allows a PSE to determine a PD's power requirements before powering, and helps with power management once power is applied. Type 2 hardware classification permits high power PSEs and PDs to determine whether the connected device can support high-power operation. A type 2 PD presents class 4 in hardware to indicate it is a high-power device. A type 1 PSE will treat a class 4 device like a class 0 device, allotting 13 W if it chooses to power the PD. A PD that receives a 2 event class understands that it is powered from a high-power PSE and it may draw up to 25.5 W immediately after the 80 ms startup period completes. A type 2 PD that does not receive a 2-event hardware classification may choose to not start, or must start in a 13 W condition and request more power through the DLL after startup. The standard requires a type 2 PD to indicate that it is underpowered if this occurs. Startup of a high-power PD under 13 W implicitly requires some form of powering down sections of the application circuits.

The maximum power entries in Table 1 determine the class the PD must advertise. The PSE may disconnect a PD if it draws more than its stated Class power, which may be the hardware class or a lower DLL-derived power level. The standard permits the PD to draw limited current peaks that increase the instantaneous power above the Table 1 limit, however the average power requirement always applies.

The WS3204 implements two-event classification. Selecting an R_{CLASS} of 63.4 Ω provides a valid type 2 signature.



High Power/High Efficiency PoE Interface and DC/DC Controller

WS3204 may be used as a compatible type 1 device simply by programming class 0–3 per Table 1. DLL communication is implemented by the ethernet communication system in the PD and is not implemented by the WS3204.

The WS3204 disables classification above V_{CU_OFF} to avoid excessive power dissipation. CLASS voltage is turned off during PD thermal limit or when ADPD or DET are active. The CLASS output is inherently current limited, but should not be shorted to V_{SS} for long periods of time.

Figure 24 shows how classification works for the WS3204. Transition from state-to-state occurs when comparator thresholds are crossed (see Figure 21 and Figure 22). These comparators have hysteresis, which adds inherent memory to the machine. Operation begins at idle (unpowered by PSE) and proceeds with increasing voltage from left to right. A 2-event classification follows the (heavy lined) path towards the bottom, ending up with a latched type 2 decode along the lower branch that is highlighted. This state results in a low T2P during normal operation. Once the valid path to type 2 PSE detection is broken, the input voltage must transition below the mark reset threshold to start anew.

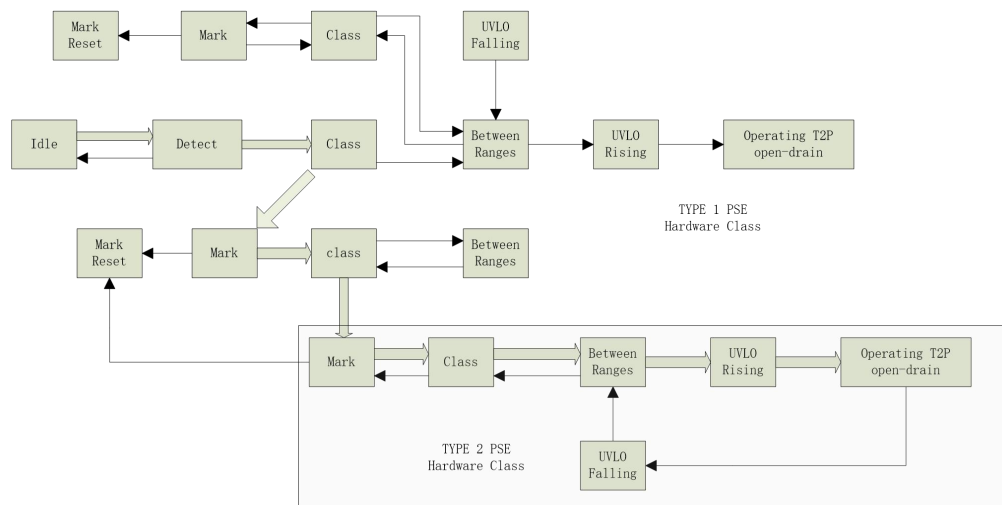

Figure 24. Two-Event Class Internal States

Inrush and Startup

802.3at has a startup current and time limitation, providing type 2 PSE compatibility for type 1 PDs. A type 2 PSE limits output current to between 400 mA and 450 mA for up to 75 ms after power-up (applying “48 V” to the PI) in order to mirror type 1 PSE functionality. The type 2 PSE will support higher output current after 75 ms. The WS3204 implements a 140 mA inrush current, which is compatible with all PSE types. A high-power PD must control its converter startup peak and operational currents drawn to below 400 mA for 80 ms. The WS3204’s internal softstart permits control of the converter startup, however the application circuits must assure that their power draw does not cause the PD to exceed the current/time limitation. This requirement implicitly requires some form of powering down sections of the application circuits. T2P becomes valid within t_{T2P} after switching starts, or if an adapter is plugged in while the PD is operating from a PSE.

Maintain Power Signature

The MPS is an electrical signature presented by the PD to assure the PSE that it is still present after operating voltage is applied. A valid MPS consists of a minimum dc current of 10 mA (or a 10 mA pulsed current for at least 75 ms every 225 ms) and an ac impedance lower than 26.25 k Ω in parallel with 0.05 μ F. The ac impedance is usually accomplished by the minimum operating C_{IN} requirement of 5 μ F. When either ADPD or DET is used to force the hotswap switch off, the dc MPS will not be met. A PSE that monitors the dc MPS will remove power from the PD when this occurs. A PSE that monitors only the ac MPS may remove power from the PD.

Startup and Converter Operation

The internal PoE UVLO (Under Voltage Lock Out) circuit holds the hotswap switch off before the PSE provides full voltage to the PD. This prevents the converter circuits from loading the PoE input during detection and classification.



High Power/High Efficiency PoE Interface and DC/DC Controller

The converter circuits will discharge C_{IN} , C_{VC} , and C_{VB} while the PD is unpowered. Thus $V_{VDD}-V_{RTN}$ will be a small voltage just after full voltage is applied to the PD, as seen in Figure 23. The PSE drives the PI voltage to the operating range once it has decided to power up the PD. When V_{VDD} rises above the UVLO turn-on threshold (V_{UVLO-R} , ~ 35 V) with RTN high, the WS3204 enables the hotswap MOSFET with a ~ 140 Ma (inrush) current limit as seen in Figure 25. Converter switching is disabled while C_{IN} charges and V_{RTN} falls from V_{VDD} to nearly V_{VSS} , however the converter startup circuit is allowed to charge C_{VC} (the bootstrap startup capacitor). Converter switching is allowed if the PD is not in inrush, OTSD is not active, and the V_C UVLO permits it. Once the inrush current falls about 10% below the inrush current limit, the PD current limit switches to the operational level (~ 970 mA). Continuing the startup sequence shown in Figure 25, V_{VC} continues to rise until the startup threshold (V_{CUV} , ~ 11 V) is exceeded, turning the startup source off and enabling switching. The V_B regulator is always active, powering the internal converter circuits as V_{VC} rises. There is a slight delay between the removal of charge current and the start of switching as the softstart ramp sweeps above the V_{ZDC} threshold. V_{VC} falls as it powers both the internal circuits and the switching MOSFET gates. If the converter control bias output rises to support V_{VC} before it falls to $V_{CUV} - V_{CUVH}$ (~ 7 V), a successful startup occurs. T2P in Figure 23 (Figure 1, $V_{T2P-OUT}$) becomes active within t_{T2P} from the start of switching, indicating that a type 2 PSE or an adapter is plugged in.

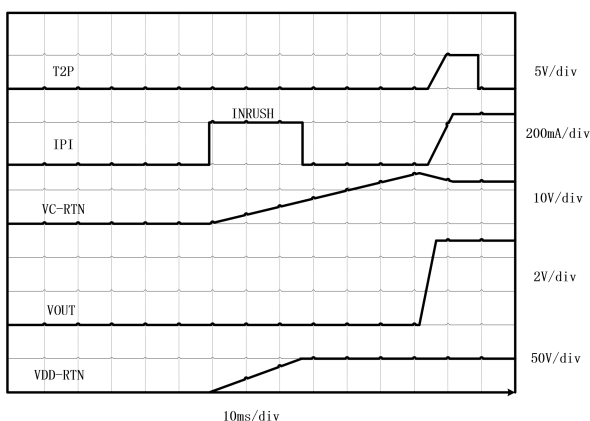

Figure 25. Power Up and Start

If $V_{VDD} - V_{VSS}$ drops below the lower PoE UVLO ($V_{UVLO-R} - V_{UVLO-H}$, ~ 30.5 V), the hotswap MOSFET is turned off, but the converter will still run. The converter will stop if V_{VC} falls below the converter UVLO ($V_{CUV} - V_{CUVH}$, ~ 7 V), the hotswap is in inrush current limit, 0% duty cycle is demanded by V_{CTRL} ($V_{CTRL} < V_{ZDC}$, ~ 1.5 V), or the converter is in thermal shutdown.

PD Hotswap Operation

IEEE 802.3at has taken a new approach to PSE output limiting. A type 2 PSE must meet an output current vs. time template with specified minimum and maximum sourcing boundaries. The peak output current may be as high as 50 A for 10 μ s or 1.75 A for 75 ms. This makes robust protection of the PD device even more important than it was in IEEE 802.3-2008.

The internal hotswap MOSFET is protected against output faults and input voltage steps with a current limit and deglitched (time-delay filtered) foldback. An overload on the pass MOSFET engages the current limit, with $V_{RTN}-V_{VSS}$ rising as a result. If V_{RTN} rises above ~ 12 V for longer than ~ 400 μ s, the current limit reverts to the inrush value, and turns the converter off. The 400 μ s deglitch feature prevents momentary transients from causing a PD reset, provided that recovery lies within the bounds of the hotswap and PSE protection. Figure 26 shows an example of recovery from a 16 V PSE rising voltage step. The hotswap MOSFET goes into current limit, overshooting to a relatively low current, recovers to ~ 950 mA full current limit, and charges the input capacitor while the converter continues to run. The MOSFET did not go into foldback because $V_{RTN}-V_{VSS}$ was below 12 V after the 400 μ s deglitch.

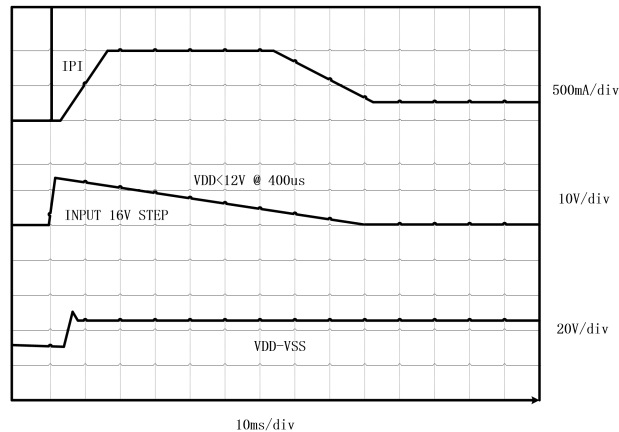

Figure 26. Response to PSE Step Voltage

The PD control has a thermal sensor that protects the internal hotswap MOSFET. Conditions like startup or operation into a V_{DD} to RTN short cause high power dissipation in the MOSFET. An over-temperature shutdown (OTSD) turns off the hotswap MOSFET and class regulator, which are restarted after the device cools. The hotswap MOSFET will be re-enabled with the inrush current limit when exiting from an over-temperature event.

Pulling DET to V_{SS} during powered operation causes the internal hotswap MOSFET to turn off. This feature allows a PD with Option three ORing per Figure 27 to achieve adapter priority. Care must be taken with synchronous converter topologies that can deliver power in both directions

The hotswap switch will be forced off under the following conditions:

1. V_{ADPD} above V_{ADPDEN} (~1.5 V)
2. V_{DET} < V_{PD-DIS} when V_{VDD}– V_{VSS} is in the operational range
3. PD over-temperature
4. (V_{VDD}– V_{VSS}) < PoE UVLO (~30.5 V).

Converter Controller Features

The WS3204 dc/dc controller implements a typical current-mode control as shown in the Functional Block Diagram. Features include oscillator, over-current and PWM comparators, current-sense blanker, dead-time control, softstart, and gate driver. In addition, an internal slope-compensation ramp generator, frequency synchronization logic, thermal shutdown, and startup current source with control are provided.

The WS3204 is optimized for isolated converters, and does not provide an internal error amplifier. Instead, the optocoupler feedback is directly fed to the CTRL pin which serves as a current-demand control for the PWM. There is an offset of V_{ZDC} (~1.5 V) and 2:1 resistor divider between the CTRL pin and the PWM. A V_{CTRL} below V_{ZDC} will stop converter switching, while voltages above (V_{ZDC} + (2 × V_{CSMAX})) will not increase the requested peak current in the switching MOSFET. Optocoupler biasing design is eased by this limited control range.

Bootstrap Topology

The internal startup current source and control logic implement a bootstrap-type startup as discussed in “Startup and Converter Operation.” The startup current source charges C_{Vc} from V_{DD1} when the converter is disabled (either by the PD control or the V_c control) to store enough energy to start the converter. Steady-state operating power must come from a converter (bias winding) output or other source. Loading on V_c and V_B must be minimal while C_{Vc} charges, otherwise the converter may never start. The optocoupler will not load V_B when the converter is off for most situations, however care should be taken in ORing topologies where the output is powered when PoE is off.

The converter will shut off when V_c falls below its lower UVLO. This can happen when power is removed from the PD, or during a fault on a converter output rail. When one output is shorted, all the output voltages fall including the one that powers V_c. The control circuit discharges V_c until it hits the lower UVLO and turns off. A restart will initiate as described in *Startup and Converter Operation* if the converter turns off and there is sufficient V_{DD1} voltage. This type of operation is sometimes referred to as *hiccup mode* which provides robust output short protection by providing time-average



heating reduction of the output rectifier.

The bootstrap control logic disables most of the converter controller circuits except the V_B regulator and internal reference. Both GATE and GATE2 (assuming GATE2 is enabled) will be low when the converter is disabled. RFRS, RBLNK, and RDT will be at ARTN while the V_C UVLO disables the converter. While the converter runs, RFRS, RBLNK, and RDT will be about 1.25 V.

The startup current source transitions to a resistance as $(V_{DD1} - V_{VC})$ falls below 7 V, but will start the converter from adapters within t_{ST} . The lower test voltage for t_{ST} was chosen based on an assumed adapter tolerance, but is not meant to imply a hard cutoff exists. Startup takes longer and eventually will not occur as V_{DD1} decreases below the test voltage. The bootstrap source provides reliable startup from widely varying input voltages, and eliminates the continual power loss of external resistors. The startup current source will not charge above the maximum recommended V_{VC} if the converter is disabled and there is sufficient V_{DD1} to charge higher.

Current Slope Compensation and Current Limit

Current-mode control requires addition of a compensation ramp to the sensed inductive (transformer or inductor) current for stability at duty cycles near and over 50%. The WS3204 has a maximum duty cycle limit of 78%, permitting the design of wide input-range flyback and active clamp converters with a lower voltage stress on the output rectifiers. While the maximum duty cycle is 78%, converters may be designed that run at duty cycles well below this for a narrower, 36 V to 57 V PI range. The WS3204 provides a fixed internal compensation ramp that suffices for most applications.

The WS3204 provides internal, frequency independent, slope compensation (150 mV, V_{SLOPE}) to the PWM comparator input for current-mode control-loop stability. This voltage is not applied to the current-limit comparator whose threshold is 0.55 V (V_{CSMAX}). If the provided slope is not sufficient, the effective slope may be increased by addition of R_s per Figure 31. The additional slope voltage is provided by $(I_{SL-EX} \times R_s)$. There is also a small dc offset caused by the $\sim 2.5 \mu$ A pin current. The peak current limit does not have duty cycle dependency unless R_s is used. This makes it easier to design the current limit to a fixed value. See *Current Slope Compensation* for more information.

The internal comparators monitoring CS are isolated from the IC pin by the blanking circuits while GATE is low, and for a short time (blanking period) just after GATE switches high. A 440 Ω (max) equivalent pull down on CS is applied while GATE is low.

Blanking - R_{RBLNK}

The WS3204 provides a choice between internal fixed and programmable blanking periods. The blanking period is specified as an increase in the minimum GATE on time over the inherent gate driver and comparator delays. The default period (see the Electrical Characteristics table) is selected by connecting RBLNK to RTN, and the programmable period is set with R_{RBLNK} .

The WS3204 blanker timing is precise enough that the traditional R-C filters on CS can be eliminated. This avoids current-sense waveform distortion, which tends to get worse at light output loads. There may be some situations or designers that prefer an R-C approach. The WS3204 provides a pull-down on CS during the GATE off time to improve sensing when an R-C filter must be used. The CS input signal should be protected from nearby noisy signals like GATE drive and the switching MOSFET drain.

Dead Time

The WS3204 features two switching MOSFET gate drivers to ease implementation of high-efficiency topologies. Specifically, these include active (primary) clamp topologies and those with synchronous drivers that are hard-driven by the control circuit. In all cases, there is a need to assure that both driven MOSFETs are not on at the same time. The RDT pin programs a fixed time period delay between the turn-off of one gate driver until the turn-on of the next. This feature is an improvement over the repeatability and accuracy of discrete solutions while eliminating a number of discrete parts on the board. Converter efficiency is easily tuned with this one repeatable adjustment. The programmed dead time is the same for both GATE-to-GATE2 and GATE2-to-GATE transitions. The dead time is triggered from internal signals that are several stages back in the driver to eliminate the effects of gate loading on the period, however the observed and actual dead-time will be somewhat dependent on the gate loading. The turnoff of GATE2 coincides with the start of the internal clock period.



High Power/High Efficiency PoE Interface and DC/DC Controller

RDT may be used to disable GATE2, which goes to a high-impedance state.

GATE's phase turns the main switch on when it transitions high, and off when it transitions low. GATE2's phase turns the second switch off when it transitions high, and on when it transitions low. Both switches should be off when GATE2 is high and GATE is low. The signal phasing is shown in Figure 2. Many topologies that use secondary-side synchronous rectifiers also use N-Channel MOSFETs driven through a gate-drive transformer. The proper signal phase for these rectifiers may be achieved by inverting the phasing of the secondary winding (swapping the leads). Use of the two gate drives is shown in Figure 1 and Figure 28.

RFRS and Synchronization

The RFRS pin programs the (free-running) oscillator frequency, and may also be used to synchronize the WS3204 converter to a higher frequency. The internal oscillator sets the maximum duty cycle at 78% and controls the slope-compensation ramp circuit. Synchronization may be accomplished by applying a short pulse (T_{SYNC}) of magnitude V_{SYNC} to RFRS as shown in Figure 30. The synchronization pulse terminates the potential on-time period, and the off-time period does not begin until the pulse terminates.

T2P, Startup and Power Management

T2P (type 2 PSE) is an active-low multifunction pin that indicates if

$[(PSE = Type_2) + (1.5\text{ V} < V_{ADPD}) + (1.55\text{ V} < V_{PSPD} < 8.3\text{ V})] \times (V_{CTRL} < 4\text{ V}) \times (pd\text{ current limit} \neq \text{Inrush})$. The term with V_{CTRL} prevents an optocoupler connected to the secondary-side from loading V_c before the converter is started. The ADPD and PSPD terms allow the PD to operate from an adapter at high-power if a type 2 PSE is not present, assuming the adapter has sufficient capacity. Applications must monitor the state of T2P to detect power source transitions. Transitions could occur when a local power supply is added or dropped or when a PSE is enabled on the far end. The PD may be required to adjust the load appropriately. The usage of T2P is demonstrated in Figure 1.

In order for a type 2 PD to operate at less than 13 W the first 80 ms after power application, the various delays must be estimated and used by the application controller to meet the requirement. The bootup time of many applications processors may be long enough to eliminate the need to do any timing.

Thermal Shutdown

The dc/dc controller has an OTSD that can be triggered by heat sources including the V_B regulator, GATE driver, bootstrap current source, and bias currents. The controller OTSD turns off V_B, the GATE driver, and forces the V_c control into an under-voltage state.

Adapter ORing

Many PoE-capable devices are designed to operate from either a wall adapter or PoE power. A local power solution adds cost and complexity, but allows a product to be used if PoE is not available in a particular installation. While most applications only require that the PD operate when both sources are present, the WS3204 supports forced operation from either of the power sources. Figure 27 illustrates three options for diode ORing external power into a PD. Only one option would be used in any particular design. Option 1 applies power to the WS3204 PoE input, option 2 applies power between the WS3204 PoE section and the power circuit, and option 3 applies power to the output side of the converter. Each of these options has advantages and disadvantages.

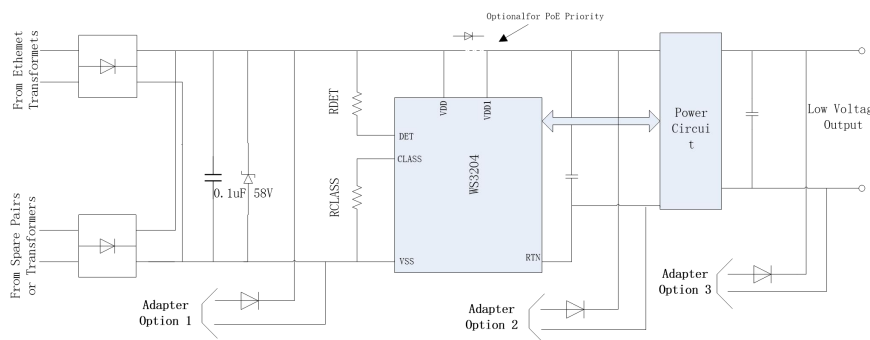

Figure 27. ORing Configurations



High Power/High Efficiency PoE Interface and DC/DC Controller

The IEEE standards require that the Ethernet cable be isolated from ground and all other system potentials. The adapter must meet a minimum 1500 Vac dielectric withstand test between the output and all other connections for ORing options 1 and 2. The adapter only needs this isolation for option 3 if it is not provided by the converter.

Adapter ORing diodes are shown for all the options to protect against a reverse voltage adapter, a short on the adapter input pins, and damage to a low-voltage adapter. ORing is sometimes accomplished with a MOSFET in option 3.

PSPD ORing Features

The WS3204 provides several additional features to ease ORing based on the multifunction PSPD pin. These include T2P signaling of an option 1 adapter, use of a 24 V adapter (reduced output power) for option 1, and use of PoE as a power backup in conjunction with option 2. See the *Advanced ORing Techniques* section.

Using DET to Disable PoE

The DET pin may be used to turn the PoE hotswap switch OFF by pulling it to V_{SS} while in the operational state, or to prevent detection when in the idle state. A low on DET forces the hotswap MOSFET OFF during normal operation.

ORing Challenges

Preference of one power source presents a number of challenges. Combinations of adapter output voltage (nominal and tolerance), power insertion point, and which source is preferred determine solution complexity. Several factors adding to the complexity are the natural high-voltage selection of diode ORing (the simplest method of combining sources), the current limit implicit in the PSE, and PD inrush and protection circuits (necessary for operation and reliability). Creating simple and seamless solutions is difficult if not impossible for many of the combinations. However the WS3204 offers several built-in features that simplify some combinations.

Several examples will demonstrate the limitations inherent in ORing solutions. Diode ORing a 48 V adapter with PoE (option 1) presents the problem that either source might be higher. A blocking switch would be required to assure which source was active. A second example is combining a 12 V adapter with PoE using option 2. The converter will draw approximately four times the current at 12 V from the adapter than it does from PoE at 48 V. Transition from adapter power to PoE may demand more current than can be supplied by the PSE. The converter must be turned off while C_{IN} capacitance charges, with a subsequent converter restart at the higher voltage and lower input current. A third example is use of a 12 V adapter with ORing option 1. The PD hotswap would have to handle four times the current, and have 1/16 the resistance (be 16 times larger) to dissipate equal power. A fourth example is that MPS is lost when running from the adapter, causing the PSE to remove power from the PD. If ac power is then lost, the PD will stop operating until the PSE detects and powers the PD.

APPLICATION INFORMATION

The WS3204 will support many power supply topologies that require a single PWM gate drive or two complementary gate drives and will operate with current-mode control. [Figure 1](#) provides an example of an active clamp forward converter that uses the second gate driver to control M2, the active element in the clamp. GATE2 may also be used to drive a synchronous rectifier as demonstrated in [Figure 28](#). The WS3204 may be used in topologies that do not require GATE2, which may be disabled to reduce its idling loss.

Selecting a converter topology along with a design procedure is beyond the scope of this applications section. Examples to help in programming the WS3204 are shown below. Additional special topics are included to explain the ORing capabilities, frequency dithering, and other design considerations.

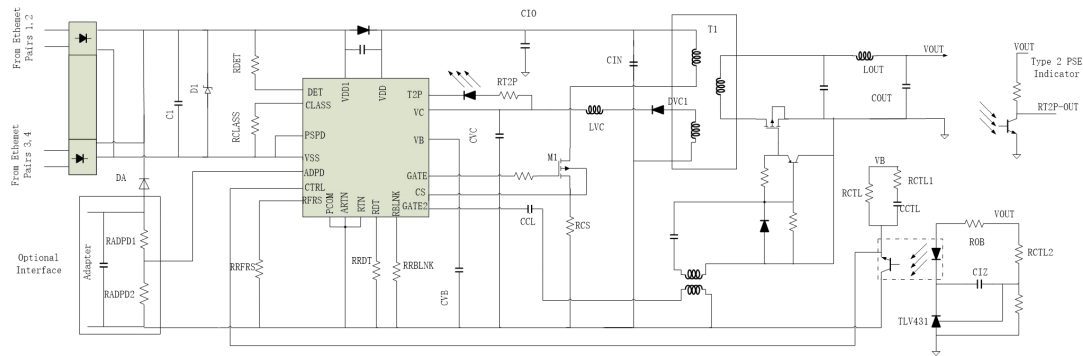
Figure 28. Driven Synchronous Flyback

Input Bridges and Schottky Diodes

Using Schottky diodes instead of PN junction diodes for the PoE input bridges and D_{VDD} will reduce the loss of this function by about 30%. There are however some things to consider when using them.

The IEEE standard specifies a maximum backfeed voltage of 2.8 V. A 100 k Ω resistor is placed between the unpowered pairs and the voltage is measured across the resistor. Schottky diodes often have a higher reverse leakage current than PN diodes, making this a harder requirement to meet. Use conservative design for diode operating temperature, select lower-leakage devices where possible, and match leakage and temperatures by using packaged bridges to help with this.

Schottky diode leakage current and lower dynamic resistance can impact the detection signature. Setting reasonable expectations for the temperature range over which the detection signature is accurate is the simplest solution. Increasing R_{DET} slightly may also help meet the requirement.

Schottky diodes have proven less robust to the stresses of ESD transients, failing as a short or becoming leaky. Care must be taken to provide adequate protection in line with the exposure levels. This protection may be as simple as ferrite beads and capacitors.

A general recommendation for the input rectifiers are 1 A or 2 A, 100 V rated discrete or bridge diodes.

Protection, D1

A TVS, D1, across the rectified PoE voltage per Figure 29 must be used. An SMAJ58A, or a part with equal to or better performance, is recommended for general indoor applications. If an adapter is connected from VDD1 to RTN, as in ORing option 2 above, voltage transients caused by the input cable inductance ringing with the internal PD capacitance can occur. Adequate capacitive filtering or a TVS must limit this voltage to be within the absolute maximum ratings. Outdoor transient levels or special applications require additional protection.

Use of diode D_{VDD} for PoE priority may dictate the use of additional protection around the WS3204. ESD events between the PD power inputs, or the inputs and converter output, cause large stresses in the hotswap MOSFET if D_{VDD} becomes reverse biased and transient current around the WS3204 is blocked. The use of C_{VDD} and D_{RTN} in Figure 29 provides additional protection should over-stress of the WS3204 be an issue. An SMAJ58A would be a good initial selection for D_{RTN}. Individual designs may have to tune the value of C_{VDD}.

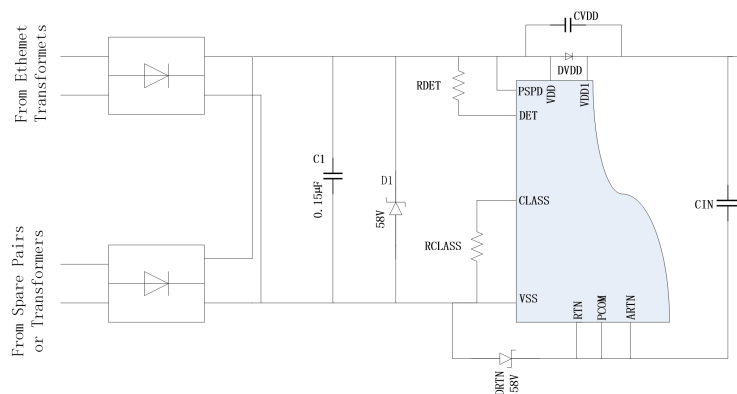

Figure 29. Example of Added ESD Protection for PoE Priority

Capacitor, C₁

The IEEE 802.3at standard specifies an input bypass capacitor (from V_{DD} to V_{SS}) of 0.05 µF to 0.12 µF. Typically a 0.1 µF, 100 V, 10% ceramic capacitor is used.

Detection Resistor, R_{DET}

The IEEE 802.3at standard specifies a detection signature resistance, R_{DET} between 23.75 kΩ and 26.25 kΩ, or 25 kΩ ± 5%. Choose an R_{DET} of 24.9 kΩ.

Classification Resistor, R_{CLASS}

Connect a resistor from CLASS to V_{SS} to program the classification current according to the IEEE 802.3at standard. The class power assigned should correspond to the maximum average power drawn by the PD during operation. Select R_{CLASS} according to Table 1.

For a high power design, choose class 4 and R_{CLASS} = 63.4 Ω.

ADPD Pin Divider Network, RADPD1, RADPD2

The ADPD pin can be used to disable the WS3204 internal hotswap MOSFET giving the adapter source priority over the PoE source.

PSPD Pin Divider Network, RPSPD1, RPSPD2

The PSPD pin can be used to override the internal hotswap MOSFET UVLO (V_{UVLO_R} and V_{UVLO_H}) when using low voltage adapters connected between V_{DD} and V_{SS}. The PSPD pin has an internal 5 µA pulldown current source. As an example, consider the choice of RPSPD1 and RPSPD2, for a 24 V adapter.

1. Select the startup voltage, VADPTR-ON approximately 75% of nominal for a 24 V adapter. Assuming that the

High Power/High Efficiency PoE Interface and DC/DC Controller

adapter output is $24\text{ V} \pm 10\%$, this provides 15% margin below the minimum adapter operating voltage.

2. Choose $V_{\text{ADPTR-ON}} = 24\text{ V} \times 0.75 = 18\text{ V}$
3. Choose $R_{\text{PSPD2}} = 3.01\text{ K}\Omega$
4. Calculate R_{PSPD1}

$$(a) R_{\text{PSPD1}} = \left(\frac{V_{\text{ADPTR-ON}} - V_{\text{PSPDEN}}}{\frac{V_{\text{PSPDEN}}}{R_{\text{PSPD2}}} - I_{\text{PSPD}}} \right) = \left(\frac{18\text{V} - 1.55\text{V}}{\frac{1.55\text{V}}{3.01\text{k}\Omega} - 5\mu\text{A}} \right) = 32.26\text{k}\Omega$$

(b) Choose $R_{\text{PSPD1}} = 32.4\text{ k}\Omega$

5. Check PSPD turn on and PSPD turn off voltages

$$(a) V_{\text{ADPTR-ON}} = V_{\text{PSPDEN}} + \left[R_{\text{PSPD1}} \times \left(\frac{V_{\text{PSPDEN}}}{R_{\text{PSPD2}}} - I_{\text{PSPD}} \right) \right] = 18.07\text{V}$$

$$(b) V_{\text{ADPTR-OFF}} = (V_{\text{PSPDEN}} - V_{\text{PSPDH}}) + \left[R_{\text{PSPD1}} \times \left(\frac{V_{\text{PSPDEN}} - V_{\text{PSPDH}}}{R_{\text{PSPD2}}} - I_{\text{PSPD}} \right) \right] = 14.54\text{V}$$

(c) Voltages look acceptable.

6. Check PSPD resistor power consumption.

$$(a) P_{\text{RPSPD}} = \frac{(V_{\text{DD}} - V_{\text{SS}})^2}{R_{\text{PSPD1}} + R_{\text{PSPD2}}} = \frac{(24\text{V} \times 1.1)^2}{3.01\text{k} + 32.4\text{k}} = 19.6\text{mW}$$

(b) Power is acceptable, but resistor values could be increased to reduce the power loss.

Setting Frequency (RRFRS) and Synchronization

The converter switching frequency is set by connecting R_{RFRS} from the RFRS pin to ARTN. The frequency may be set as high as 1 MHz with some loss in programming accuracy as well as converter efficiency. Synchronization at high duty cycles may become more difficult above 500 kHz due to the internal oscillator delays reducing the available on-time. As an example:

1. Assume a desired switching frequency (f_{sw}) of 250 kHz.
2. Compute R_{RFRS} :

$$(a) R_{\text{RFRS}}(\text{k}\Omega) = \frac{17250}{f_{\text{sw}}(\text{kHz})} = \frac{17250}{250} = 69$$

(b) Select 69.8 k Ω .

The WS3204 may be synchronized to an external clock to eliminate beat frequencies from a sampled system, or to place emission spectrum away from an RF input frequency. Synchronization may be accomplished by applying a short pulse (T_{SYNC}) of magnitude V_{SYNC} to RFRS as shown in Figure 30. R_{RFRS} should be chosen so that the maximum free-running frequency is just below the desired synchronization frequency. The synchronization pulse terminates the potential on-time period, and the off-time period does not begin until the pulse terminates. The pulse at the RFRS pin should reach between 2.5 V and V_{B} , with a minimum width of 22 ns (above 2.5 V) and rise/fall times less than 10 ns. The RFRS node should be protected from noise because it is high-impedance. An R_{T} on the order of 100 Ω in the isolated example reduces noise sensitivity and jitter.

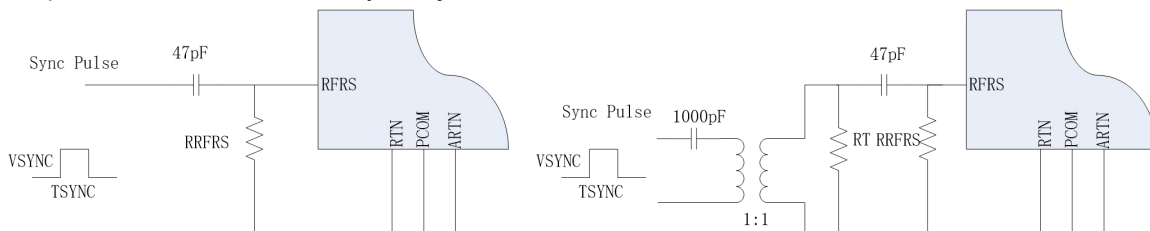

Figure 30. Synchronization

Current Slope Compensation

The WS3204 provides a fixed internal compensation ramp that suffices for most applications. R_s (see Figure 31) may be used if the internally provided slope compensation is not enough.

Most current-mode control papers and application notes define the slope values in terms of V_{PP}/T_s (peak ramp voltage / switching period), however the electrical characteristics table specifies the slope peak (V_{SLOPE}) based on the maximum (78%) duty cycle. Assuming that the desired slope, $V_{SLOPE-D}$ (in mV/period), is based on the full period, compute R_s per the following equation where V_{SLOPE} , D_{MAX} , and I_{SL-EX} are from the electrical characteristics table with voltages in mV, current in μA , and the duty cycle is unitless (e.g., $D_{MAX} = 0.78$).

$$R_s(\Omega) = \frac{\left[V_{SLOPE-D}(\text{mV}) - \left(\frac{V_{SLOPE}(\text{mV})}{D_{MAX}} \right) \right]}{I_{SL-EX}(\mu A)} \times 1000 \quad (6)$$

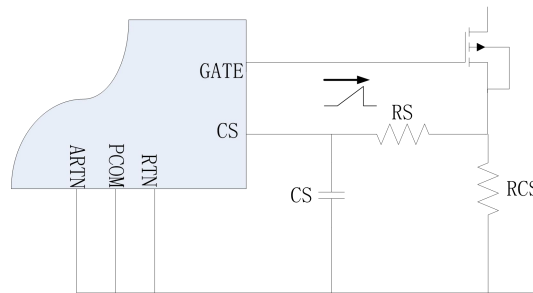

Figure 31. Additional Slope Compensation

C_s may be required if the presence of R_s causes increased noise, due to adjacent signals like the gate drive, to appear at the C_s pin.

Blanking Period, R_{RBLNK}

Selection of the blanking period is often empirical because it is affected by parasitics and thermal effects of every device between the gate-driver and output capacitors. The minimum blanking period prevents the current limit and PWM comparators from being falsely triggered by the inherent current spike that occurs when the switching MOSFET turns on. The maximum blanking period is bounded by the output rectifier's ability to withstand the currents experienced during a converter output short.

If blanking beyond the internal default is desired choose R_{RBLNK} using $R_{RBLNK}(k\Omega) = t_{RBLNK}(ns)$.

1. For a 100 ns blanking interval
 - (a) $R_{RBLNK}(k\Omega) = 100$
 - (b) Choose $R_{RBLNK} = 100 k\Omega$.

The blanking interval can also be chosen as a percentage of the switching period.

1. Compute R_{RBLNK} as follows for 2% blanking interval in a switcher running at 250 kHz.

$$(a) R_{RBLNK}(k\Omega) = \frac{\text{Blanking_interval}}{f_{SW}(\text{kHz})} \times 10^4 = \frac{2}{250} \times 10^4 = 80$$

- (b) Select $R_{RBLNK} = 80.6 k\Omega$.

Dead Time Resistor, R_{RDT}

The required dead time period depends on the specific topology and parasitics. The easiest technique to obtain the optimum timing resistor is to build the supply and tune the dead time to achieve the best efficiency after considering all corners of operation (load, input voltage, and temperature). A good initial value is 100 ns. Program the dead time with a resistor connected from R_{DT} to $ARTN$ per Equation 3.

1. Choose R_{RDT} as follows assuming a t_{RDT} of 100 ns:

$$(a) R_{RDT}(k\Omega) = \frac{t_{RDT}(ns)}{2} = \frac{100}{2} = 50$$



(b) Choose $R_{RDT} = 49.9 \text{ k}\Omega$

Estimating Bias Supply Requirements and C_{VC}

The bias supply (V_C) power requirements determine the C_{VC} sizing and frequency of hiccup during a fault. The first step is to determine the power/current requirements of the power supply control, then use this to select C_{VC} . The control current draw will be assumed constant with voltage to simplify the estimate, resulting in an approximate value.

First determine the switching MOSFET gate drive power.

1. Let V_{QG} be the gate voltage swing that the MOSFET Q_G is rated to (often 10 V).

$$(a) P_{GATE} = V_C \times f_{SW} \times \left(Q_{GATE} \times \frac{V_C}{V_{QG}} \right) \quad P_{GATE2} = V_C \times f_{SW} \times \left(Q_{GATE2} \times \frac{V_C}{V_{QG}} \right)$$

(b) Compute gate drive power if V_C is 12 V, Q_{GATE} is 17 nC, and Q_{GATE2} is 8 nC.

$$P_{GATE} = 12V \times 250kHz \times 17nC \times \frac{12}{10} = 61.2mW$$

$$P_{GATE2} = 12V \times 250kHz \times 8nC \times \frac{12}{10} = 28.8mW$$

$$(c) P_{DRIVE} = 61.2mW + 28.8mW = 90mW$$

(d) This illustrates why MOSFET Q_G should be an important consideration in selecting the switching MOSFETs.

2. Estimate the required bias current at some intermediate voltage during the C_{VC} discharge. For the WS3204, 12 V provides a reasonable estimate. Add the operating bias current to the gate drive current.

$$(a) I_{DRIVE} = \frac{P_{DRIVE}}{V_C} = \frac{90mW}{12V} = 7.5mA$$

$$(b) I_{TOTAL} = I_{DRIVE} + I_{OPERATING} = 7.5mA + 0.92mA = 8.42mA$$

3. Compute the required C_{VC} based on startup within the typical softstart period of 4 ms.

$$(a) C_{VC1} + C_{VC2} = \frac{T_{STARUP} \times I_{TOTAL}}{V_{CUVH}} = \frac{4ms \times 8.42mA}{6.5V} = 5.18\mu F$$

(b) For this case, a standard 10 μF electrolytic plus a 0.47 μF should be sufficient.

4. Compute the initial time to start the converter when operating from PoE.

(a) Using a typical bootstrap current of 4 mA, compute the time to startup.

$$(b) T_{ST} = \frac{C_{VC1} \times V_{CUH}}{I_{VC}} = \frac{10.47\mu F \times 15V}{4mA} = 39ms$$

5. Compute the fault duty cycle and hiccup frequency

$$(a) T_{RECHARGE} = \frac{(C_{VC1} + C_{VC2}) \times V_{CUVH}}{I_{VC}} = \frac{(10\mu F + 0.47\mu F) \times 6.5V}{4mA} = 17ms$$

$$(b) T_{DISCHARGE} = \frac{(C_{VC1} + C_{VC2}) \times V_{CUVH}}{I_{TOTAL}} = \frac{(10\mu F + 0.47\mu F) \times 6.5V}{8.42mA} = 8.08ms$$

(c) Note that the optocoupler current is 0 mA because the output is in current limit.

Also, it is assumed I_{T2P} is 0 mA.

$$\text{Duty Cycle: } D = \frac{T_{DISCHARGE}}{T_{DISCHARGE} + T_{RECHARGE}} = \frac{8.08ms}{8.08ms + 17ms} = 32\%$$

$$(d) \text{Hiccup Frequency: } F = \frac{1}{T_{DISCHARGE} + T_{RECHARGE}} = \frac{1}{8.08ms + 17ms} = 39.9Hz$$

6. With the WS3204, the voltage rating of C_{Vc1} and C_{Vc2} should be 25 V minimum

Switching Transformer Considerations and R_{vc}

Care in design of the transformer and V_c bias circuit is required to obtain hiccup overload protection. Leading-edge voltage overshoot on the bias winding may cause V_c to peak-charge, preventing the expected tracking with output voltage. Some method of controlling this is usually required. This may be as simple as a series resistor, or an R-C filter in front of D_{Vc1}. Good transformer bias-to-output-winding coupling results in reduced overshoot and better voltage tracking.

R_{vc} as shown in Figure 32 helps to reduce peak charging from the bias winding. This becomes especially important when tuning hiccup mode operation during output overload. Typical values for R_{vc} will be between 10Ω and 100Ω.

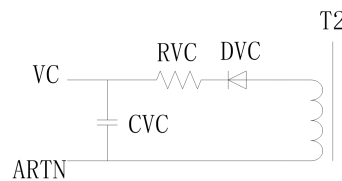

Figure 32. Rvc Usage

T2P Pin Interface

The T2P pin is an active low, open-drain output indicating a high power source is available. An optocoupler is typically used to interface with the T2P pin to signal equipment on the secondary side of the converter of T2P status. Optocoupler current-gain is referred to as CTR (current transfer ratio), which is the ratio of transistor collector current to LED current. To preserve efficiency, a high-gain optocoupler (250% ≤ CTR ≤ 500%, or 300% ≤ CTR ≤ 600%) along with a high-impedance (e.g., CMOS) receiver are recommended. Design of the T2P optocoupler interface can be accomplished as follows:

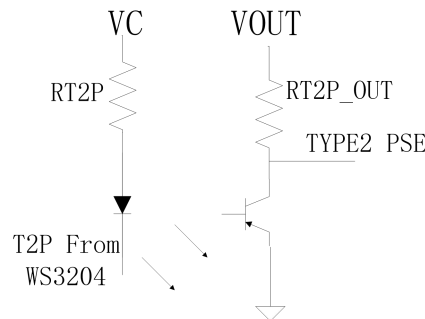

Figure 33. T2P Interface

1. T2P ON characteristic: I_{T2P} = 2 mA minimum, V_{T2P} = 1 V
2. Let V_c = 12 V, V_{OUT} = 5 V, R_{T2P-OUT} = 10 kΩ, V_{T2P-OUT (low)} = 400 mV max

$$(a) I_{RT2P-OUT} = \frac{V_{OUT} - V_{T2P-OUT(low)}}{R_{T2P-OUT}} = \frac{5 - 0.4}{10000} = 0.46mA$$

3. The optocoupler CTR will be needed to determine R_{T2P}. A device with a minimum CTR of 300% at 5 Ma LED bias current is selected. CTR will also vary with temperature and LED bias current. The strong variation of CTR with diode current makes this a problem that requires some iteration using the CTR versus I_{DIODE} curve on the optocoupler data sheet.
 - (a) Using the (normalized) curves, a current of 0.4 mA to 0.5 mA is required to support the output current at the minimum CTR at 25°C.
 - (a) Pick an I_{DIODE}. For example one around the desired load current
 - (b) Use the optocoupler datasheet curve to determine the effective CTR at this operating current. It is usually necessary to apply the normalized curve value to the minimum specified CTR. It might be necessary to ratio or offset the curve readings to obtain a value that is relative to the current that the CTR is specified at.
 - (c) If I_{DIODE} × CTR_{I_{DIODE}} is substantially different from I_{RT2P-OUT}, choose another I_{DIODE} and repeat.
 - (b) This manufacturer's curves also indicate a -20% variation of CTR with temperature. The approximate forward

High Power/High Efficiency PoE Interface and DC/DC Controller

voltage of the optocoupler diode is 1.1 V from the data sheet.

$$I_{RT2P} \cong I_{\text{MIN}} \times \frac{100}{100 - \Delta \text{CTR}_{\text{TEMP}}} = 0.5\text{mA} \times \frac{100}{100 - 20} = 0.625\text{mA}$$

(c) $V_{\text{FLED}} = 1.1 \text{ V}$

$$R_{T2P} = \frac{V_C - V_{T2P} - V_{\text{FLED}}}{I_{RT2P}} = \frac{12 - 1 - 1.1}{0.625\text{mA}} = 15.48\text{k}\Omega$$

(d) Select a 15.4 kΩ resistor. Even though the minimum CTR and temperature variation were considered, the designer might choose a smaller resistor for a little more margin.

Advanced ORing Techniques

The material in sections *Adapter ORing* and *Protection, D1* are important to consider as well. The following applications are unique to the WS3204 with the introduction of PSPD.

Option 2 ORing with PoE acting as a hot backup is eased by connecting PSPD to V_{DD} per **Figure 34**. This PSPD connection enables the class regulator even when ADPD is high. The R-Zener network (1.8 kΩ – 24 V) is the simplest circuit that will satisfy MPS requirements, keeping the PSE online. This network may be switched out when the ADPD is not powered with an optocoupler. This works best with a 48-V adapter and the ADPD-programmed threshold as high as possible. An example of an adapter priority application with smooth switchover between a 48 V adapter and PoE is shown on the right side of **Figure 34**. D_{ADPD} is used to reduce the effective ADPD hysteresis, allowing the PSE to power the load before $V_{\text{DD1}} - V_{\text{RTN}}$ falls too low and causes a hotswap foldback.

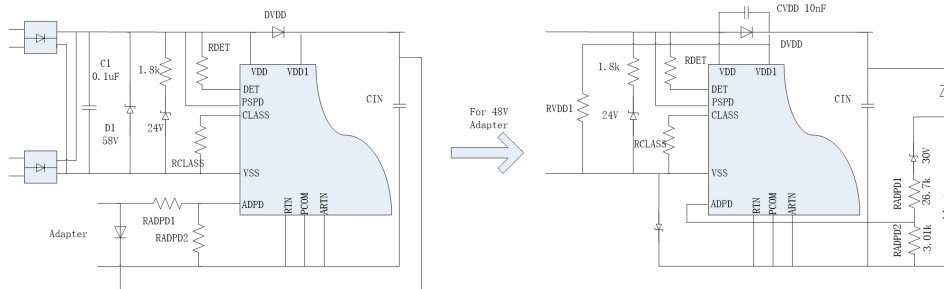

Figure 34. Option 2 PoE Backup ORing

Option 1 ORing of a low voltage adapter (e.g., 24 V) is possible by connecting a resistor divider to PSPD as in **Figure 35**. When $1.55 \text{ V} \leq V_{\text{PSPD}} \leq 8.3 \text{ V}$, the hotswap MOSFET is enabled, T2P is activated, and the class feature is disabled. The hotswap current limit is unaffected, limiting the available power. For example, the maximum input power from a 24 V adapter would be 19.3 W [(24 V – 0.6 V) × 0.825 A].

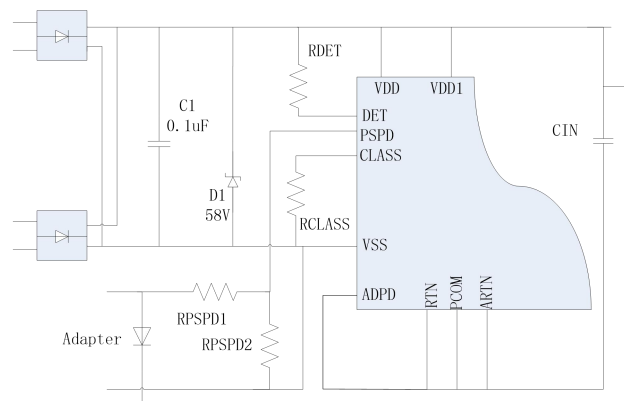

Figure 35. Low-Voltage Option 1 ORing

Softstart

Converters require a softstart on the voltage error amplifier to prevent output overshoot on startup. **Figure 36** shows a common implementation of a secondary-side softstart that works with the typical TL431 error amplifier. The softstart



High Power/High Efficiency PoE Interface and DC/DC Controller

components consist of D_{SS} , R_{SS} , and C_{SS} . They serve to control the output rate-of-rise by pulling V_{CTRL} down as C_{SS} charges through R_{OB} , the optocoupler, and D_{SS} . This has the added advantage that the TL431 output and C_{IZ} are preset to the proper value as the output voltage reaches the regulated value, preventing voltage overshoot due to the error amplifier recovery. The secondary-side error amplifier will not become active until there is sufficient voltage on the secondary. The WS3204 provides a primary-side softstart which persists long enough (~4 ms) for secondary side voltage-loop softstart to take over. The primary-side current-loop softstart controls the switching MOSFET peak current by applying a slowly rising ramp voltage to a second PWM control input. The PWM is controlled by the lower of the softstart ramp or the CTRL-derived current demand. The actual output voltage rise time is usually much shorter than the internal softstart period. Initially the internal softstart ramp limits the maximum current demand as a function of time. Either the current limit, secondary-side softstart, or output regulation assume control of the PWM before the internal softstart period is over. Figure 25 shows a smooth handoff between the primary and secondary-side softstart with minimal output voltage overshoot.

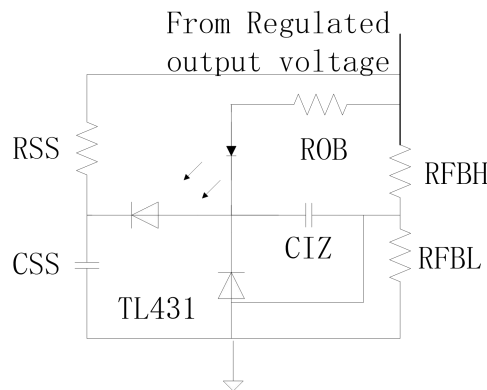

Figure 36. Error Amplifier Soft Start



Special Switching MOSFET Considerations

Special care must be used in selecting the converter switching MOSFET. The WS3204 minimum switching MOSFET V_{GATE} is ~ 5.5 V, which is due to the V_c lower threshold. This will occur during an output overload, or towards the end of a (failed) bootstrap startup. The MOSFET must be able to carry the anticipated peak fault current at this gate voltage

Thermal Considerations and OTSD

Sources of nearby local PCB heating should be considered during the thermal design. Typical calculations assume that the WS3204 is the only heat source contributing to the PCB temperature rise. It is possible for a normally operating WS3204 device to experience an OTSD event if it is excessively heated by a nearby device.

Frequency Dithering for Conducted Emissions Control

The international standard CISPR 22 (and adopted versions) is often used as a requirement for conducted emissions. Ethernet cables are covered as a telecommunication port under section 5.2 for conducted emissions. Meeting EMI requirements is often a challenge, with the lower limits of Class B being especially hard. Circuit board layout, filtering, and snubbing various nodes in the power circuit are the first layer of control techniques. A more detailed discussion of EMI control is presented in *Practical Guidelines to Designing an EMI Compliant PoE Powered Device With Isolated Flyback*. Additionally, IEEE802.3at sections 33.3 and 33.4 have requirements for noise injected onto the Ethernet cable based on compatibility with data transmission.

Occasionally, a technique referred to as frequency dithering is utilized to provide additional EMI measurement reduction. The switching frequency is modulated to spread the narrowband individual harmonics across a wider bandwidth, thus lowering peak measurements. The circuit of Figure 37 modulates the switching frequency by feeding a small ac signal into the RFRS pin. These values may be adapted to suit individual needs.

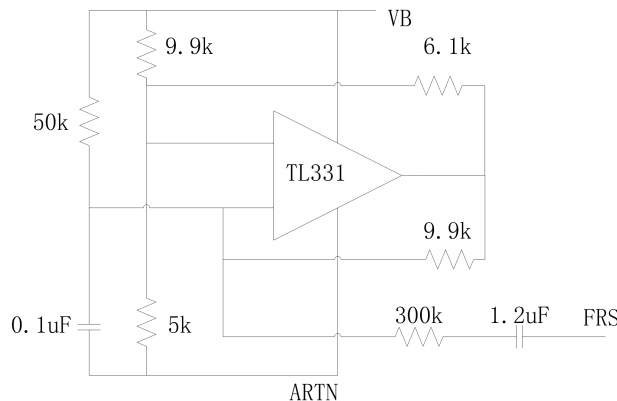

Figure 37. Frequency Dithering

ESD

The WS3204 has been tested to EN61000-4-2 using a power supply based on Figure 1. The levels used were 8 kV contact discharge and 15 kV air discharge. Surges were applied between the PoE input and the dc output, between the adapter input and the dc output, between the adapter and the PoE inputs, and to the dc output with respect to earth. Tests were done both powered and unpowered. No WS3204 failures were observed and operation was continuous. See Figure 29 for additional protection for some test configurations.

Layout

Printed circuit board layout recommendations are provided in the evaluation module (EVM) documentation available for these devices.



PACKAGE MATERIALS INFORMATION

DEVICE PACKAGE TYPE: HTSSOP-20

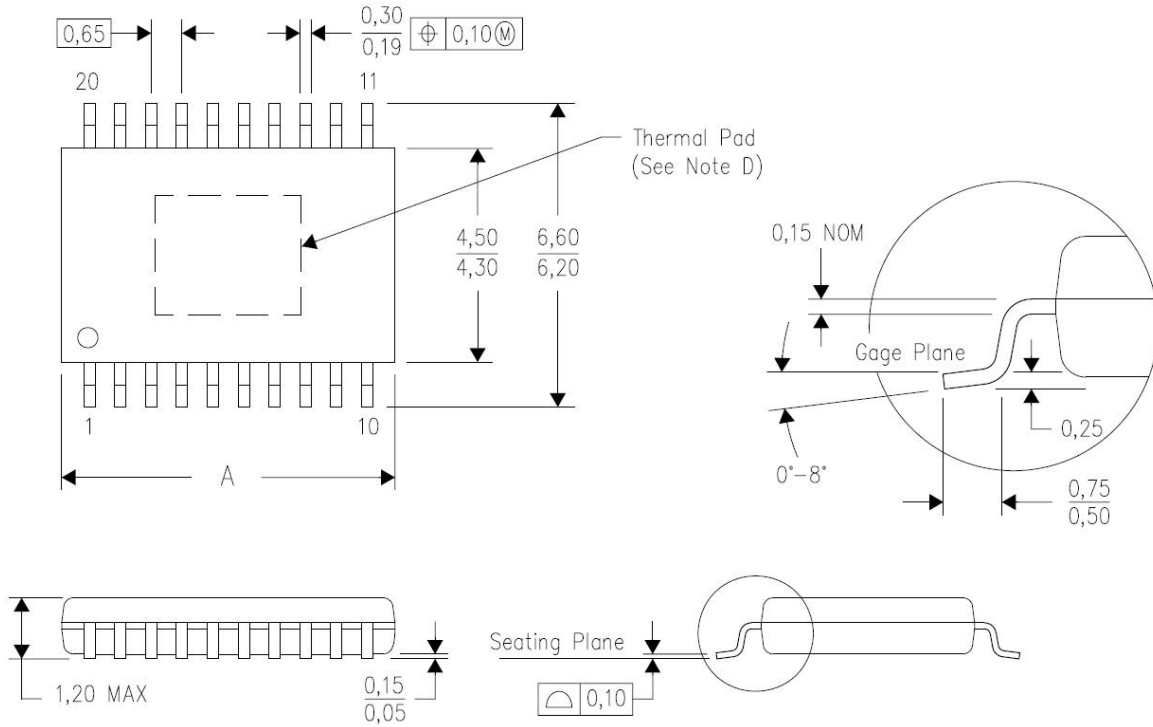

NOTES:

- A. All linear dimensions are in millimeters.
- B. This drawing is subject to change without notice.
- C. Body dimensions do not include mold flash or protrusions .Mold flash and protrusion shall not exceed 0.15 per side.
- D. This package is designed to be soldered to a thermal pad on the board.



THERMAL PAD MECHANICAL DATA

This HTSSOP package incorporates an exposed thermal pad that is designed to be attached to a printed circuit board (PCB). The thermal pad must be soldered directly to the PCB. After soldering, the PCB can be used as a heatsink. In addition, through the use of thermal vias, the thermal pad can be attached directly to the appropriate copper plane shown in the electrical schematic for the device, or alternatively, can be attached to a special heatsink structure designed into the PCB. This design optimizes the heat transfer from the integrated circuit (IC).

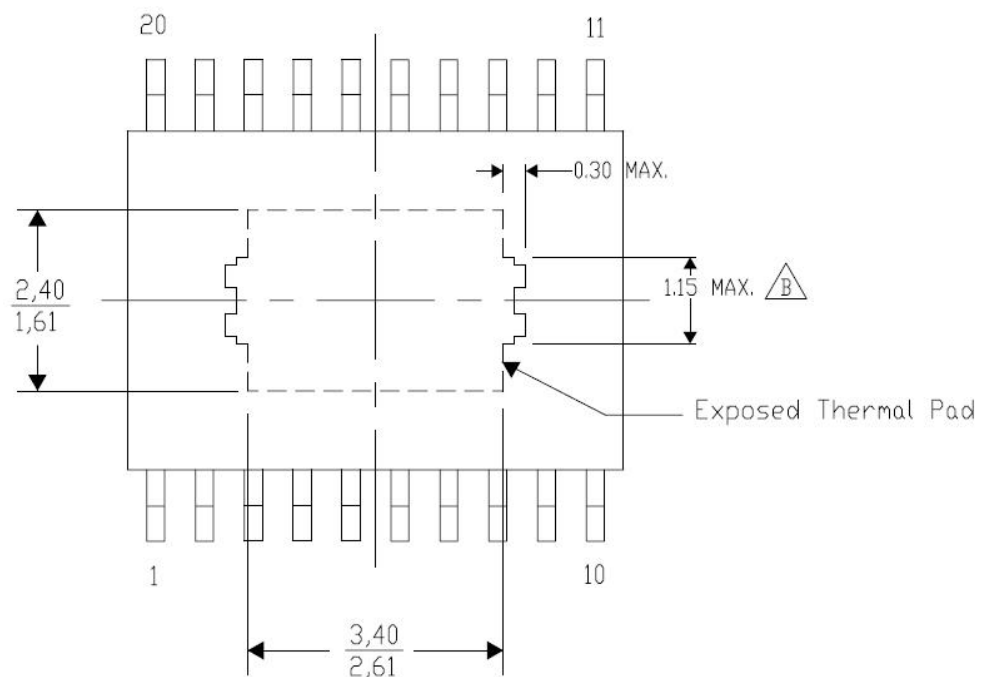

NOTE: A. All linear dimensions are millimeters
B. Exposed tie strap features may not be present.

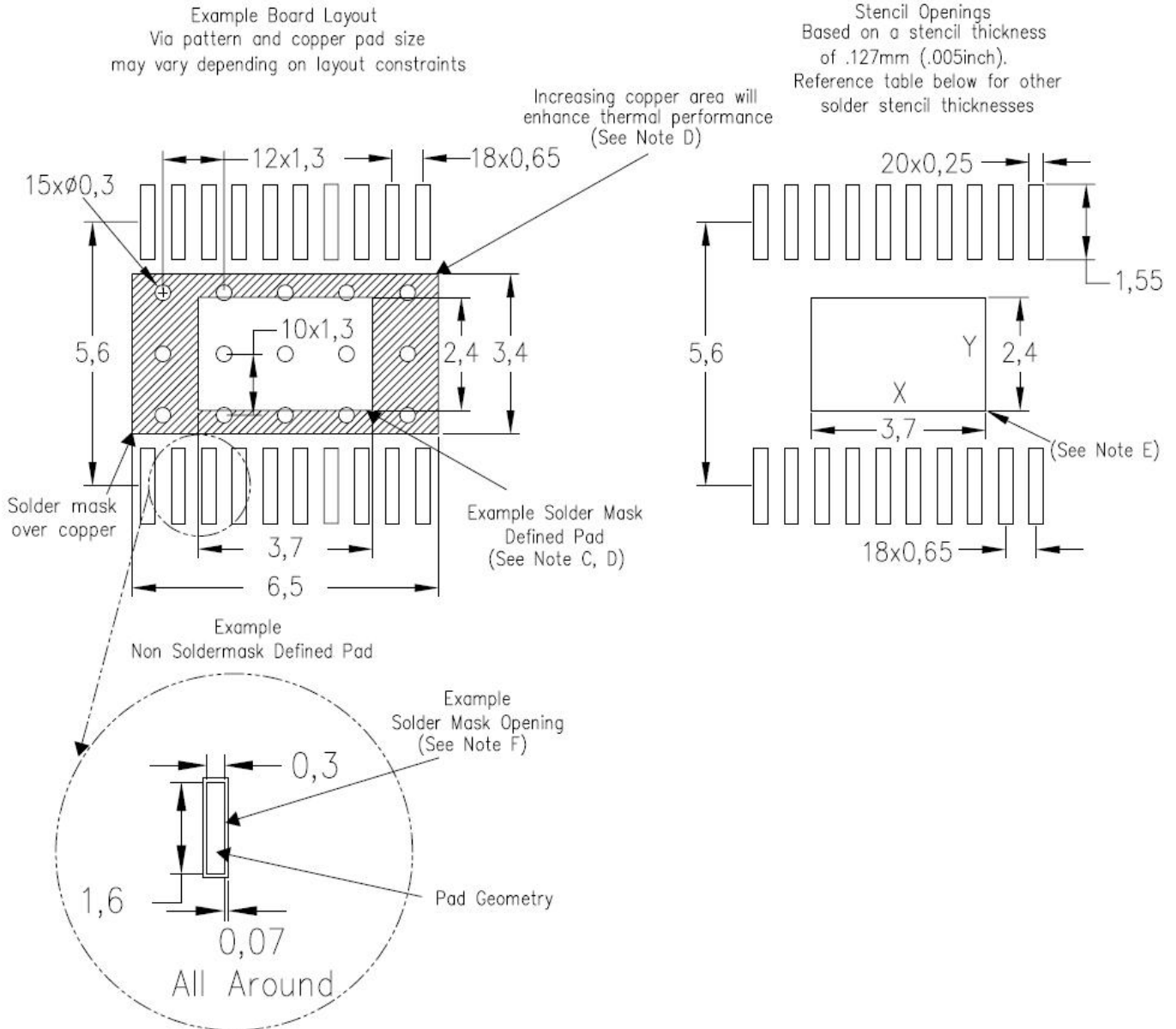
LAND PATTERN DATA

- NOTES:
- A. All linear dimensions are in millimeters.
 - B. This drawing is subject to change without notice.
 - C. Customer should place a note on the circuit board fabrication drawing not to alter the center solder mask defined pad.
 - D. This package is designed to be soldered to a thermal pad on the board.
 - E. Laser cutting apertures with trapezoidal walls and also rounding corners will offer better paste release. Customers should contact their board assembly site for stencil design recommendations.
 - F. Customers should contact their board fabrication site for solder tolerances between and signal pads.