

产品规格书 SPECIFICATION

客户名称 CUSTOMER	
产品名称 PRODUCTION	超声波传感器
产品型号 MODEL	SY-SMD-2481
版本号 VERSION NO	A1.0

广东赛亚传感股份有限公司

地址:广东省东莞市东城街道白银钱五巷2号

[http:// www.saiyasensor.com](http://www.saiyasensor.com) www.saiyasensor.com

<http://www.saia.cn> www.saia.cn

mail: sensor@saiyasensor.com sy@saia.cn



客户确认 CUSTOMER CONFIRMATION	审核 CHECKED BY	编制 PREPARED BY
	李柄	钟小易

声明

本说明书版权属广东赛亚传感股份有限公司(以下称本公司)所有, 未经书面许可, 本说明书任何部分不得复制、翻译、存储于数据库或检索系统内, 也不可以电子、翻拍、录音等任何手段进行传播。

感谢您使用广东赛亚的系列产品。为使您更好地使用本公司产品, 减少因使用不当造成的产品故障, 使用前请务必仔细阅读本说明书并按照所建议的使用方法进行使用。如果用户不依照本说明书使用或擅自去除、拆解、更换传感器内部组件, 本公司不承担由此造成的任何损失。

您所购买产品的颜色、款式及尺寸以实物为准。

本公司秉承科技进步的理念, 不断致力于产品改进和技术创新。因此, 本公司保留任何产品改进而不预先通知的权力。使用本说明书时, 请确认其属于有效版本。同时, 本公司鼓励使用者根据其使用情况, 探讨本产品更优化的使用方法。

请妥善保管本说明书, 以便在您日后需要时能及时查阅并获得帮助。

广东赛亚传感股份有限公司

A. SCOPE

This specification applies Ultrasonic Sensor

B. SPECIFICATION

No.	Item	Unit	Specification
1	Construction		Open
2	Using method		Transmitter 发射
3	Nominal Frequency	Hz	25.0±1K
4	Transmitting Sensitivity	dB	Min.115at 25.0kHz/10Vms/30cm/0dB=20uPa
5	Directivity	deg	(80°, -6 dB)
6	Capacitance	pF	2800±25% @1KHz
7	Allowable input voltage	Vrms	80 @25KHz
8	Operating Temperature	°C	-20 ~ +80
9	Storage Temperature	°C	-30 ~ +80
10	Housing material		Auminium
11	Leading Pin		Tin Plated Brass(Sn) See appearance drawing
12	Environmental Protection Regulation		RoHS
13	Weight (MAX)	g	2.5

C. APPEARANCE DRAWING

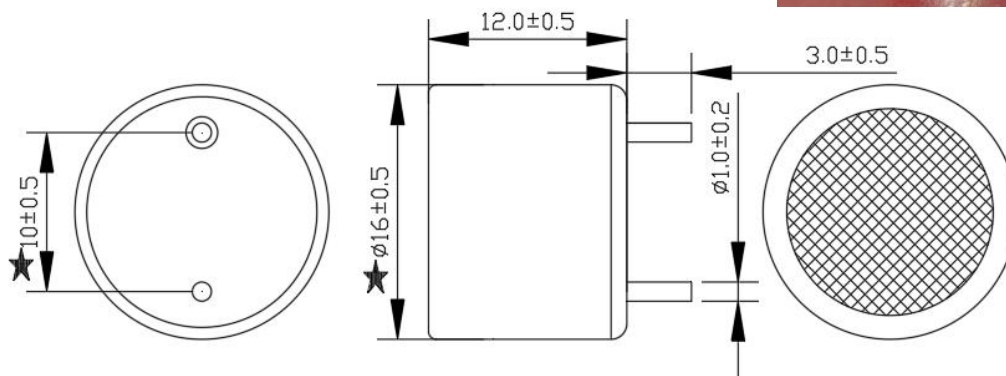

Tol : ± 0.5

Unit: mm

D. TESTING METHOD

Standard Measurement conditions

Temperature: $25 \pm 2^\circ\text{C}$ Humidity: 45-65%

Acoustic Characteristics:

The oscillation frequency, current consumption and sound pressure are measured by the measuring instruments shown below

Receiver

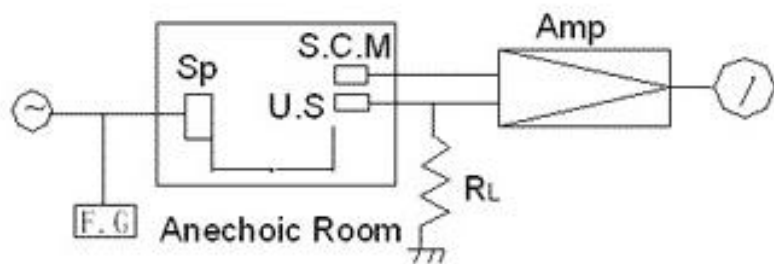

RL: $3.9\text{K}\Omega$
 U.S. :Ultrasonic Sensor
 S.C.M:Standard Cappacitor Microphone
 Amp. :Amplifier
 OSC. :Oscillator
 Sp :Tweeter
 F.C :Frequency Counter

Transmitter

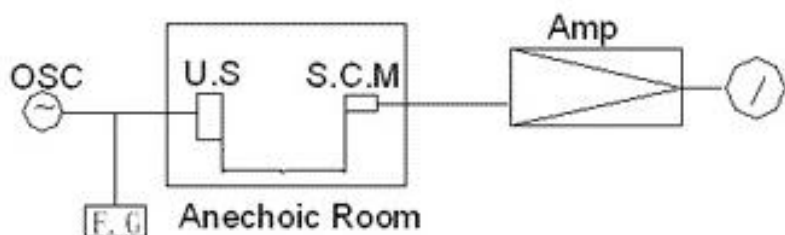

U.S. :Ultrasonic Sensor
 S.C.M:Standard Cappacitor Microphone
 Amp. :Amplifier
 Input voltage: 10Vrms
 F.C :Frequency Counter

In the measuring test, buzzer is placed as follows:

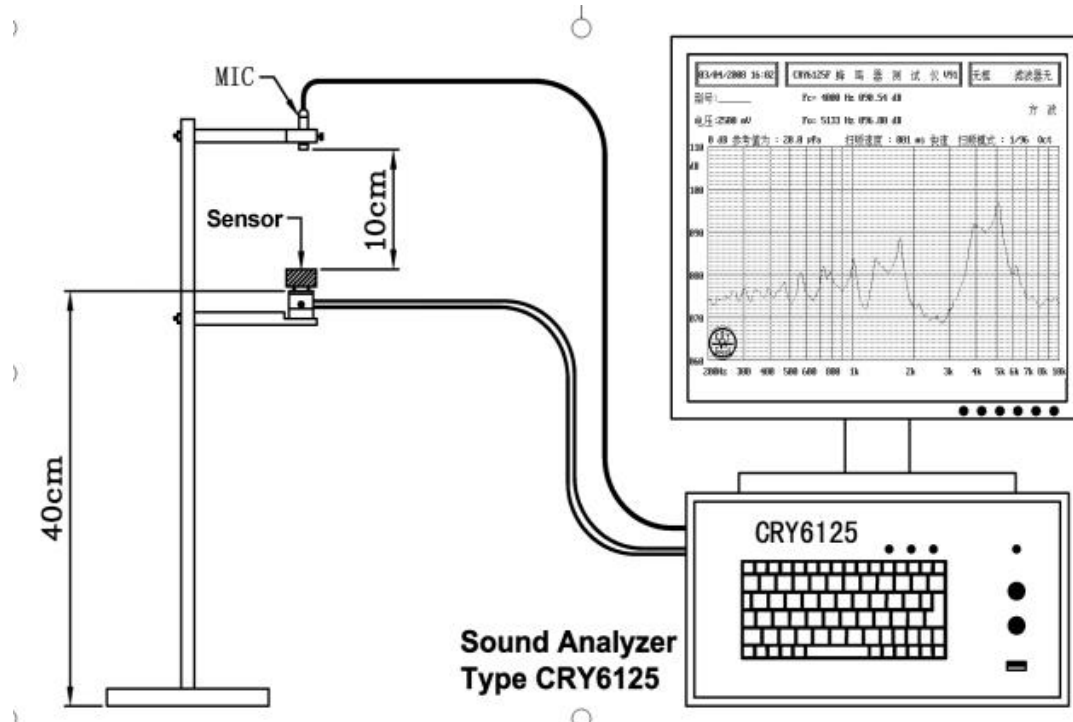

E. Typical Frequency Response Curve

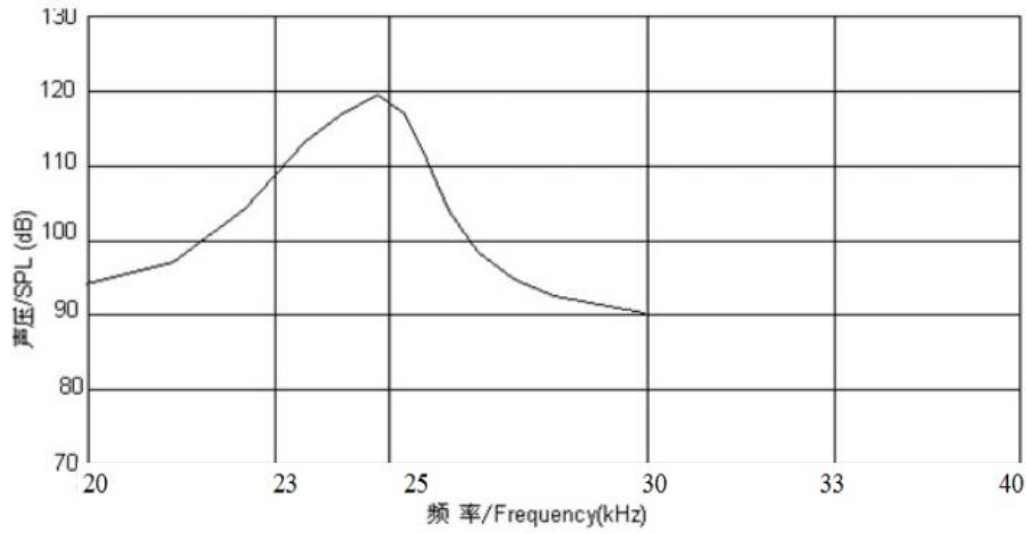

声压-频率特性图/SPL-Frequency Characteristics

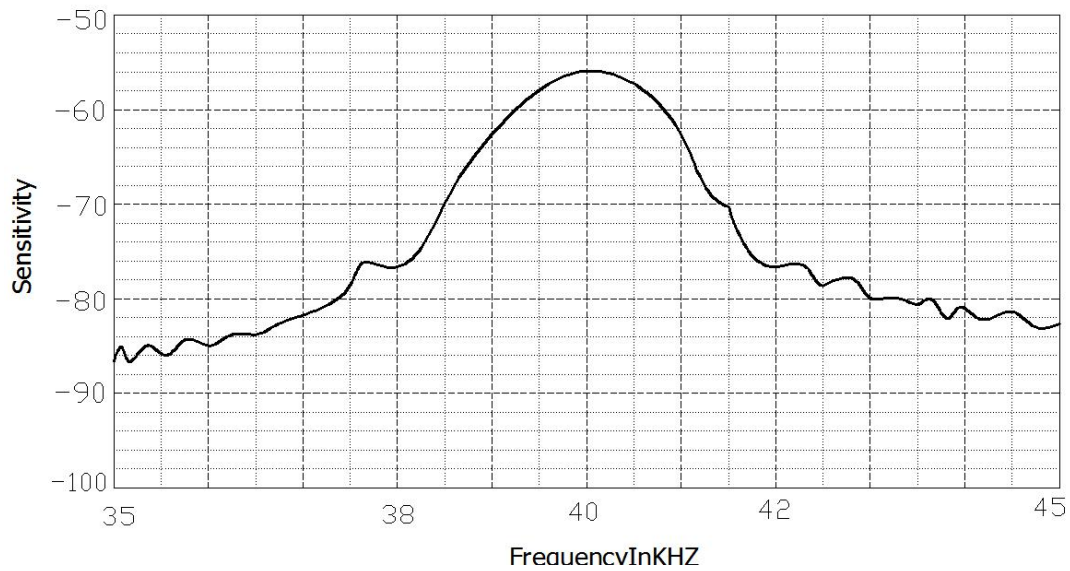

指向性示意图

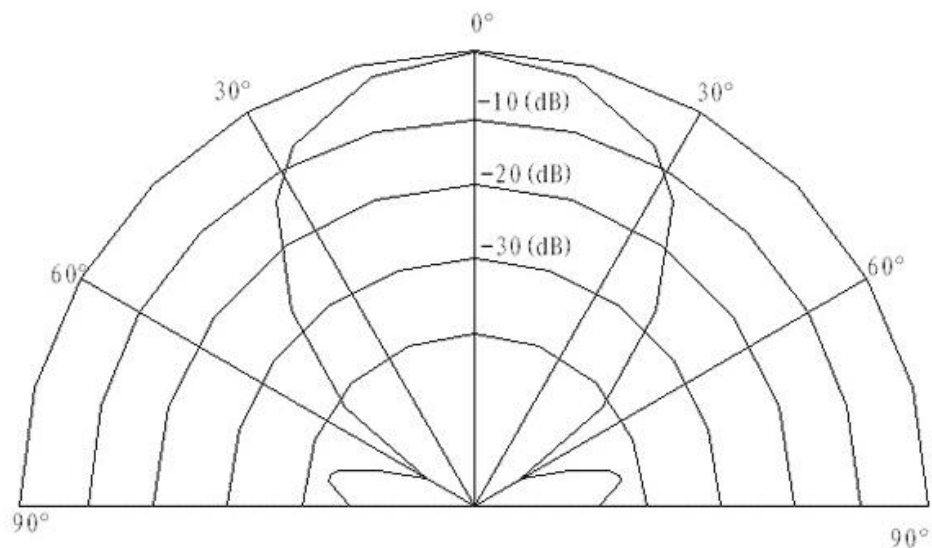

Directivity in Overall Sensitivity

F. RELIABILITY TEST

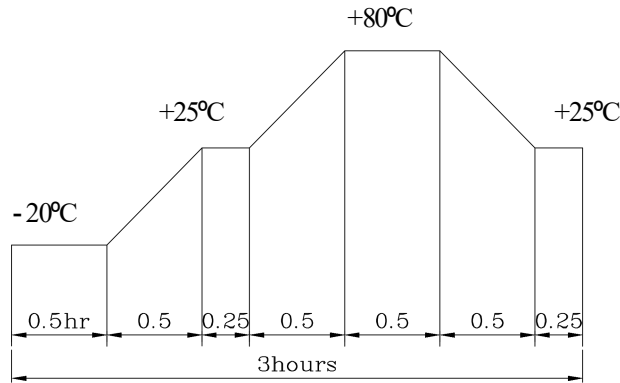
NO.	ITEM	TEST CONDITION AND REQUIREMENT
1	High Temperature Test (Storage)	After being placed in a chamber with 80 ± 2 for 96 hours and then being placed in normal condition for 2 hours. Allowable variation of SPL after test: ± 10 dB.
2	Low Temperature Test (Storage)	After being Placed in a chamber with -20 ± 2 for 96 hours and then being placed in normal condition for 2 hours. Allowable variation of SPL after test: ± 10 dB.
3	Humidity Test	After being Placed in a chamber with 90-95% R.H. at 40 ± 2 for 96 hours and then being placed in normal condition for 2 hours. Allowable variation of SPL after test: ± 10 dB.
4	Temperature Cycle Test	<p>The part shall be subjected to 5 cycles. One cycle shall be consist of:</p>  <p>Allowable variation of SPL after test: ± 10dB.</p>
5	Drop Test	Drop on a hard wood board of 4cm thick, any directions ,6 times, at the height of 75cm . Allowable variation of SPL after test: ± 10 dB.
6	Vibration Test	After being applied vibration of amplitude of 1.5mm with 10 to 55 Hz band of vibration frequency to each of 3 perpendicular directions for 2 hours . Allowable variation of SPL after test: ± 10 dB.
7	Solderability Test	Lead terminals are immersed in rosin for 5 seconds and then immersed in solder bath of $+300 \pm 5$ for 3 1 seconds . 90% min. lead terminals shall be wet with solder (Except the edge of terminals).
8	Terminal Strength Pulling Test	The force of 9.8N(1.0kg) is applied to each terminal in axial direction for 10 seconds. No visible damage and cutting off.

TEST CONDITION.

Standard Test Condition	:	a) Temperature : $+5 \sim +35^{\circ}\text{C}$	b) Humidity : 45-85%	c) Pressure : 860-1060mbar
一般测试条件	:	a) 温度 : $+5 \sim +35^{\circ}\text{C}$	b) 湿度 : 45-85%	c) 气压 : 860-1060mbar
Judgment Test Condition	:	a) Temperature : $+25 \pm 2^{\circ}\text{C}$	b) Humidity : 60-70%	c) Pressure : 860-1060mbar
争议时测试条件	:	a) 温度 : $+25 \pm 2^{\circ}\text{C}$	b) 湿度 : 60-70%	c) 气压 : 860-1060mbar

G. PACKING STANDARD

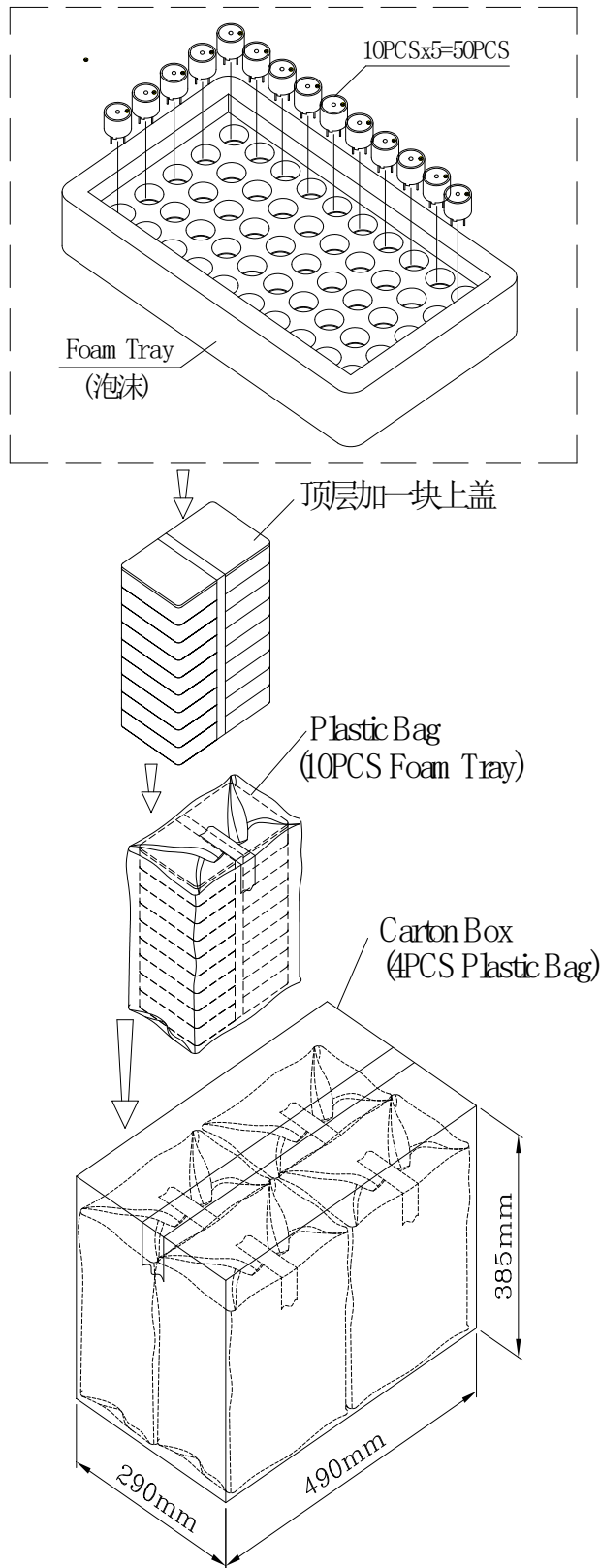

广东赛亚传感股份有限公司

地址: 广东省东莞市东城街道白银钱五巷2号

<http://www.saiyasensor.com> www.saiyasensor.com

www.saia.cn www.saiacn.net

Email: sensor@saiyasensor.com

Foam Tray	230mm x135mm x35mm	1x50PCS=50PCS
Plastic Bag		10x50PCS=500PCS
Carton Box	490mm x290mm x385mm	4x500PCS=2000PCS