

DIP8, DC Input, 2.5A, Gate Driver Photo Coupler

Description

The SL 3120R series combine an AlGaAs infrared emitting diode as the emitter which is optically coupled to an integrated circuit with a power output stage in a plastic DIP8 package with different lead forming options.

Features

- High isolation 5000 VRMS
- DC input with a high speed driver
- Operating temperature range - 40 °C to 100 °C
- Rail to rail output
- REACH & RoHS compliance
- Halogen free (Optional)
- MSL class 1

Applications

- Isolated IGBT/Power MOSFET gate drive
- Industrial Inverter
- AC brushless and DC motor drives
- Induction Heating

SCHEMATIC

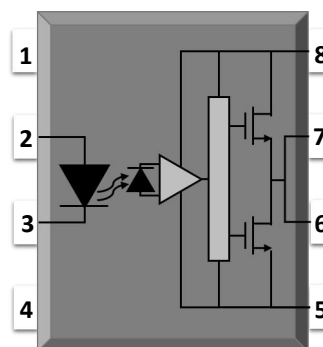

PIN DEFINITION

1.NC	8.VCC
2.Anode	7.VO
3.Cathode	6.VO
4.NC	5.GND

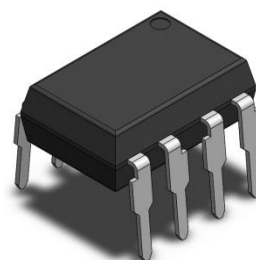

SL3120R DIP-8

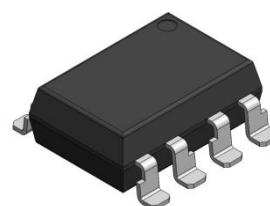

SL3120RS SMD-8

ABSOLUTE MAXIMUM RATINGS				
PARAMETER	SYMBOL	VALUE	UNIT	Note
INPUT				
Forward Current	IF	25	mA	
Peak Forward Current	IFP	50	mA	1
Peak Transient Current	IF(trans)	1	A	2
Operating Frequency	f	50	kHz	
Reverse Voltage	VR	5	V	
Input Power Dissipation	PI	100	mW	
OUTPUT				
Supply Voltage	VCC	35	V	
Output Voltage	VO	35	V	
Peak Output Current	IO	2.5	A	
Output Power Dissipation	PO	250	mW	
COMMON				
Total Power Dissipation	Ptot	295	mW	
Isolation Voltage	Viso	5000	Vrms	3
Distance Through Insulation	Dti	0.5	mm	
Operating Temperature	Topr	-55~100	°C	
Storage Temperature	Tstg	-55~125	°C	
Soldering Temperature	Tsol	260	°C	4

Note 1. 50% duty, 1ms P.W

Note 2. $\leq 1\mu\text{s}$ P.W, 300pps

Note 3. AC For 1 Minute, R.H. = 40 ~ 60%

Note 4. For 10 seconds

TRUTH TABLE			
LED	VDD-VSS "Positive Going" (Turn-on)	VDD-VSS "Negative Going" (Turn-off)	VO
Off	0V to 30V	0V to 30V	Low
On	0V to 11.5V	0V to 10V	Low
On	11.5V to 13.5V	10V to 12V	Transition
On	13.5V to 30V	12V to 30V	High

RECOMMENDED OPERATION CONDITIONS

PARAMETER	SYMBOL	MIN.	MAX.	UNIT
Operating Temperature	TA	-40	100	°C
Supply Voltage	VCC	15	30	V
Input Current (ON)	IF(ON)	7	16	mA
Input Voltage (OFF)	VF(OFF)	0	0.8	V

ELECTRICAL OPTICAL CHARACTERISTICS (VCC=30V, VEE=GND, TA=25°C unless specified otherwise)

PARAMETER	SYMBOL	MIN.	TYP.	MAX.	UNIT	TEST CONDITION	NOTE
INPUT CHARACTERISTICS							
Forward Voltage	VF	-	1.38	1.8	V	IF=10mA	
Reverse Current	IR	-	-	10	µA	VR=5V	
Input Capacitance	Cin	-	13	-	pF	V=0, f=1MHz	
OUTPUT CHARACTERISTICS							
High Level Supply Current	ICCH	-	1.66	3	mA	IF= 7mA to 10mA, VO= Open	
Low Level Supply Current	ICCL	-	1.8	3	mA	VF = 0 to 0.8V, VO= Open	
TRANSFER CHARACTERISTICS							
High Level Output Voltage	VOH	VCC-0.3	VCC-0.1	-	V	IF= 10mA, IO= -100mA	
Low Level Output Voltage	VOL	-	VEE+0.1	VEE+0.25	V	IF= 0mA, IO= 100mA	
High Level Output Current	IOPH	-1	-	-	A	VO= VCC-1.5V	
		-2.5	-	-	A	VO= VCC-4V	
Low Level Output Current	IOPL	1	-	-	A	VO= VEE+1.5V	
		2.5	-	-	A	VO= VEE+4V	
Input Threshold Current	IFLH	-	2.38	5	mA	IO= 0mA, VO> 5V	
Input Threshold Voltage	VFHL	0.8	-	-	V	IO= 0mA, VO< 5V	
Under Voltage Lockout Threshold	VUVLO+	11	13.01	13.5	V	IO= 10mA, VO> 5V	
	VUVLO-	9.5	11.01	12	V	IO= 10mA, VO< 5V	
Isolation Resistance	Riso	10 ¹²	10 ¹⁴	-	Ω	DC500V, 40 ~ 60% R.H.	
Floating Capacitance	CIO	-	1.0	-	pF	V=0, f=1MHz	

ELECTRICAL OPTICAL CHARACTERISTICS (VCC=30V, VEE=GND, TA=25°C unless specified otherwise)							
PARAMETER	SYMBOL	MIN.	TYP.	MAX.	UNIT	TEST CONDITION	NOTE
SWITCHING CHARACTERISTICS							
Propagation Delay Time to Output Low Level	TPHL	50	103	500	ns	IF= 7 to 16mA, CL= 10nF, RL= 10Ω, f= 10kHz, Duty = 50%, TA= 25 °C	
Propagation Delay Time to Output High Level	TPLH	50	83	500	ns		
Pulse Width Distortion	TPHL-TPLH	-	20	200	ns		
Propagation Delay Skew	tPSK	-100	-	100	ns		
Rise Time	tr	-	13	-	ns		
Fall Time	tf	-	13	-	ns		
UVLO Turn On Delay	tUVLO(ON)	-	1.6	-	μs	IF= 10mA, VO> 5V	
UVLO Turn Off Delay	tUVLO(OFF)	-	0.4	-	μs	IF= 10mA, VO< 5V	
Common Mode Transient Immunity at Logic High	CMH	-20	-	-	kV/μs	IF=7 to 16mA VCC= 30V, TA= 25 °C, VCM= 2kV	
Common Mode Transient Immunity at Logic Low	CML	20	-	-	kV/μs	IF=0mA VCC= 30V, RL, TA= 25 °C, VCM= 2kV	

CHARACTERISTIC CURVES

Fig.1 Forward Current vs. Forward Voltage

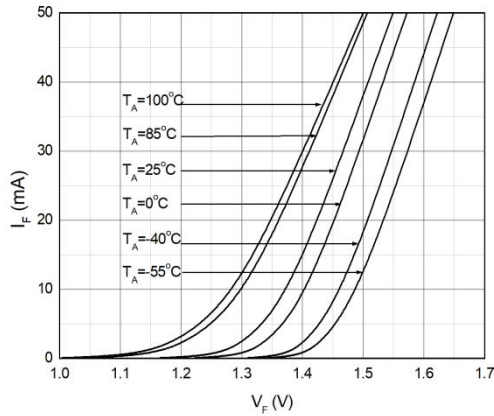

Fig.2 Forward Voltage vs. Ambient Temperature

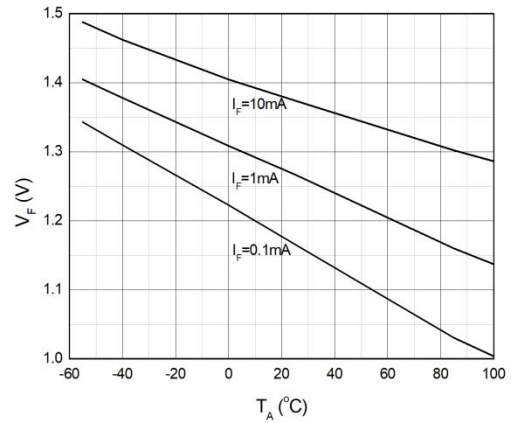

Fig.3 Supply Current vs. Ambient Temperature

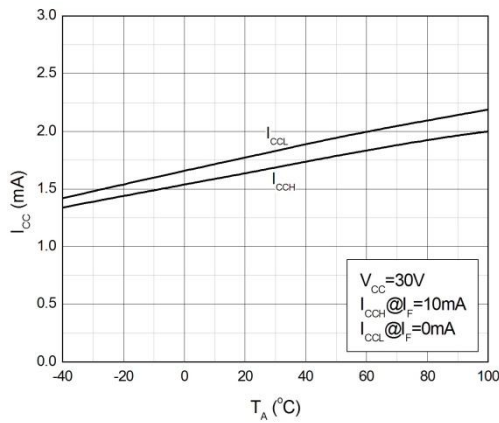

Fig.4 Supply Current vs. Supply Voltage

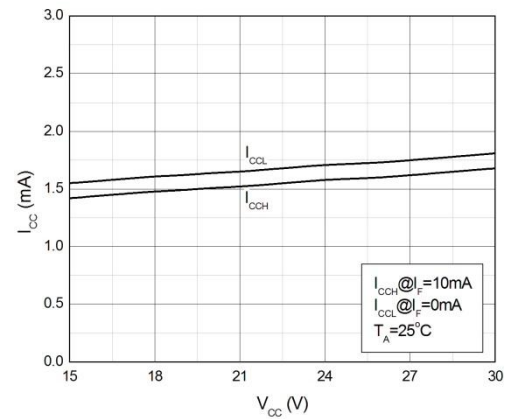

Fig.5 High Level Output Voltage vs. High Level Output Current

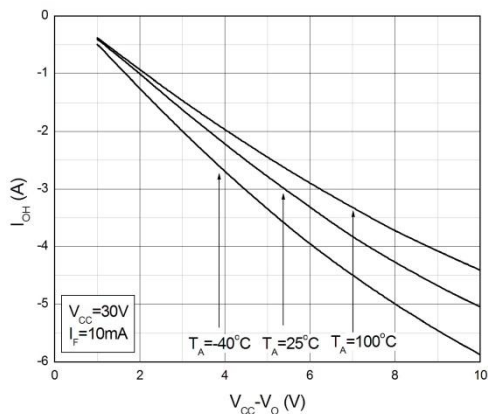
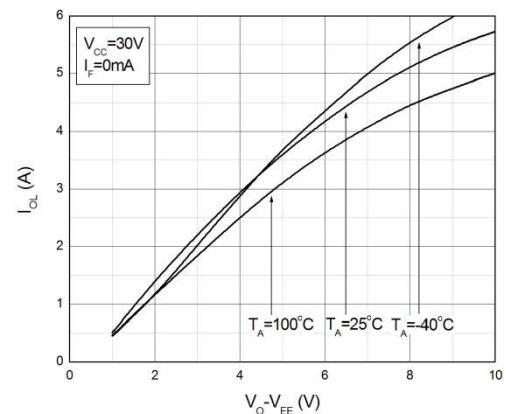

Fig.6 Low Level Output Voltage vs. Low Level Output Current



CHARACTERISTIC CURVES

Fig.7 High Level Output Voltage vs. Ambient Temperature

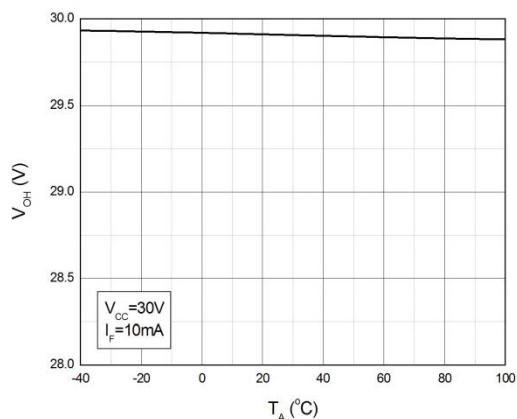

Fig.8 Low Level Output Voltage vs. Ambient Temperature

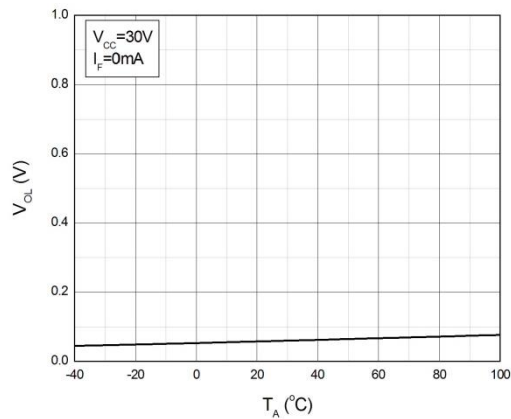

Fig.9 Output Voltage vs. Forward Current

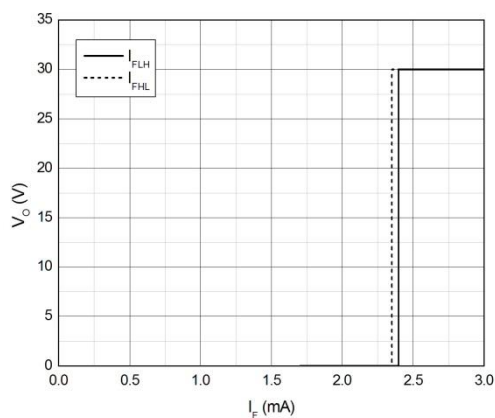

Fig.10 Output Voltage vs. Supply Voltage

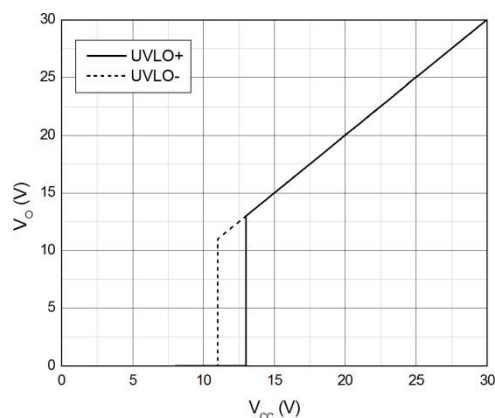

Fig.11 Forward Current vs. Ambient Temperature

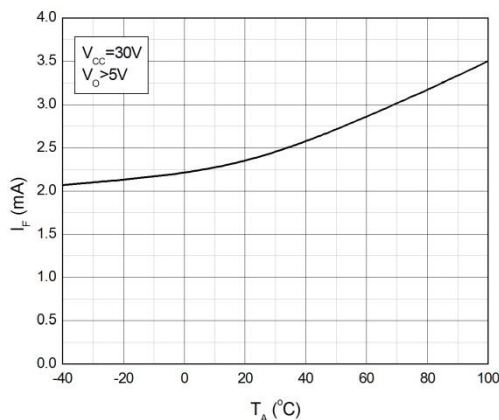
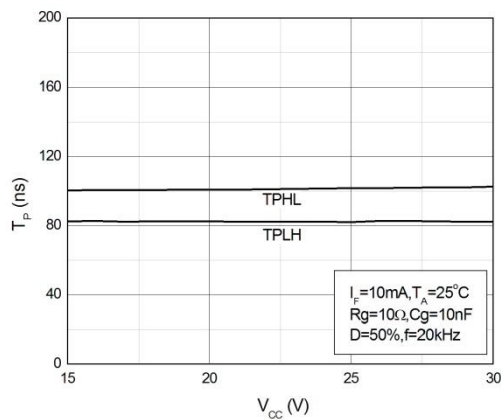

Fig.12 Propagation Delay vs. Supply Voltage



CHARACTERISTIC CURVES

Fig.13 Propagation Delay vs. Forward Current

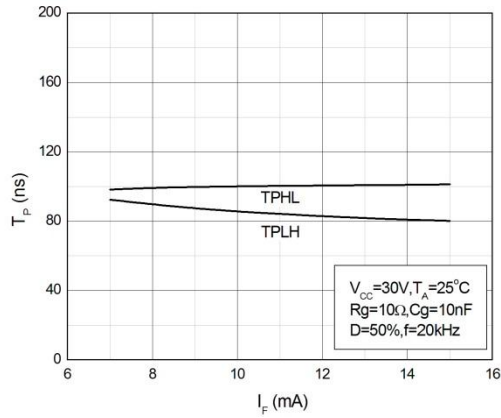

Fig.14 Propagation Delay vs. Ambient Temperature

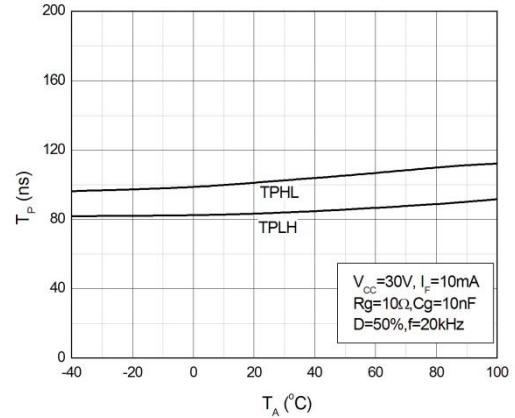

Fig.15 Propagation Delay vs. Load Resistance

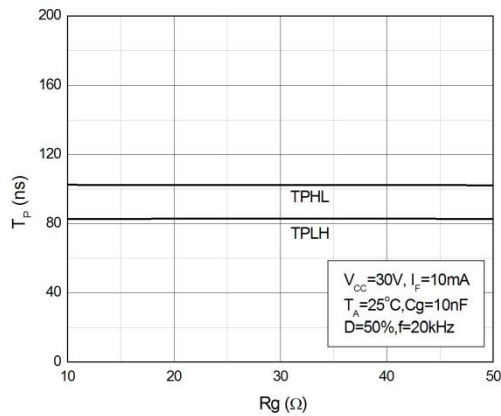
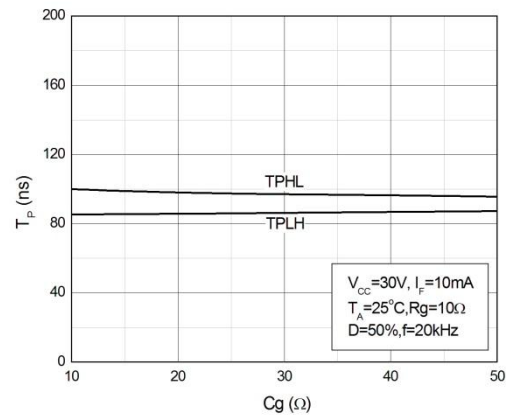

Fig.16 Propagation Delay vs. Load Capacitance



TEST CIRCUITS

Fig.17 Test Circuits for IOH

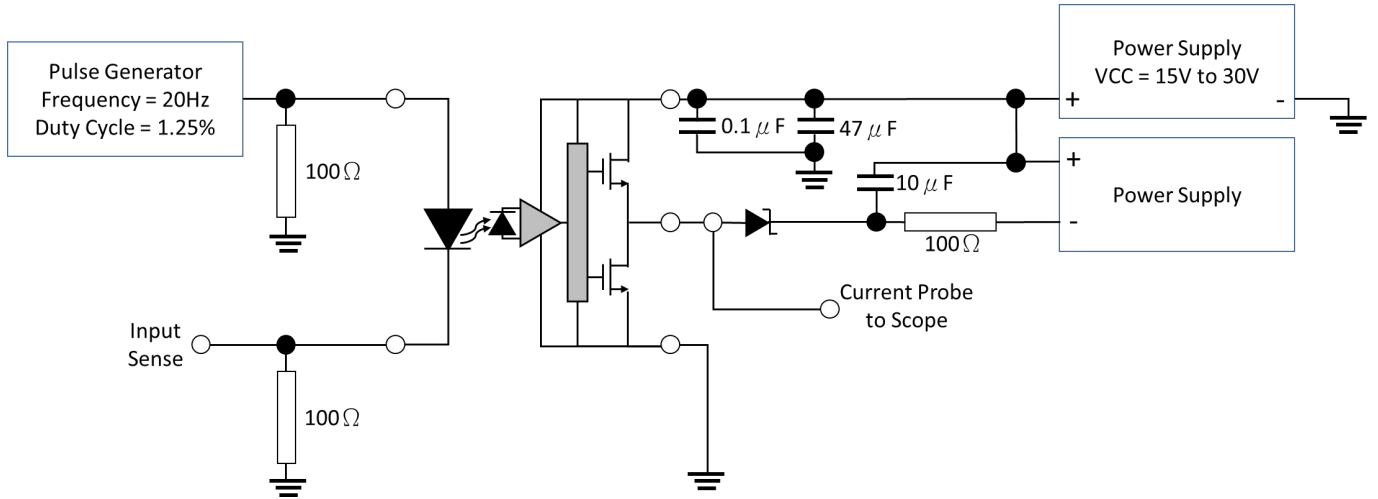
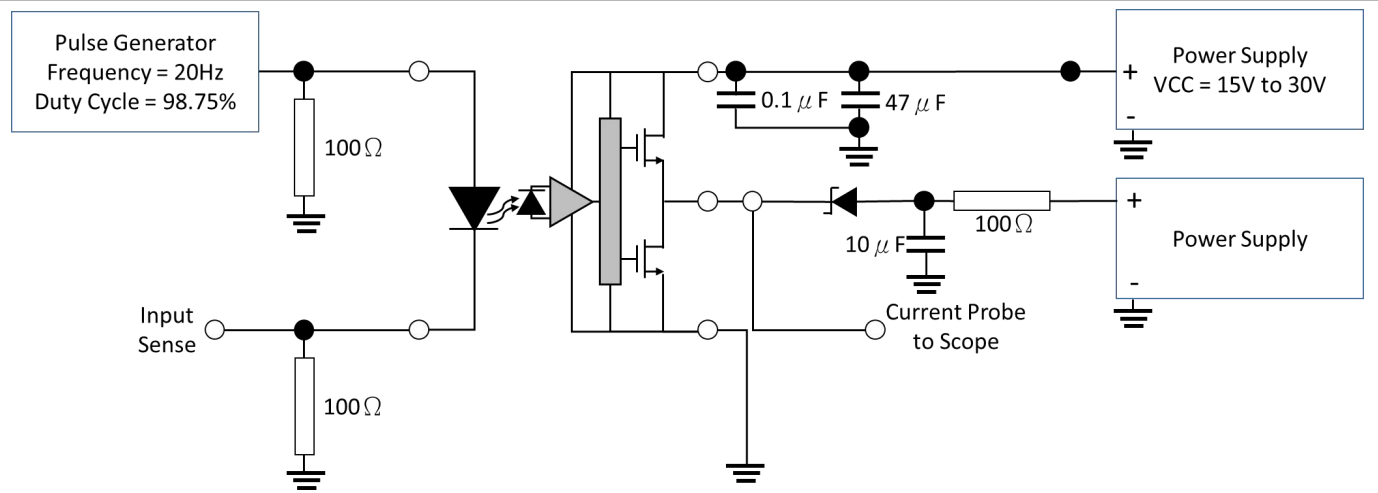

Fig.18 Test Circuits for IOL



TEST CIRCUITS

Fig.19 Test Circuits for TPHL, TPLH, tr, tf

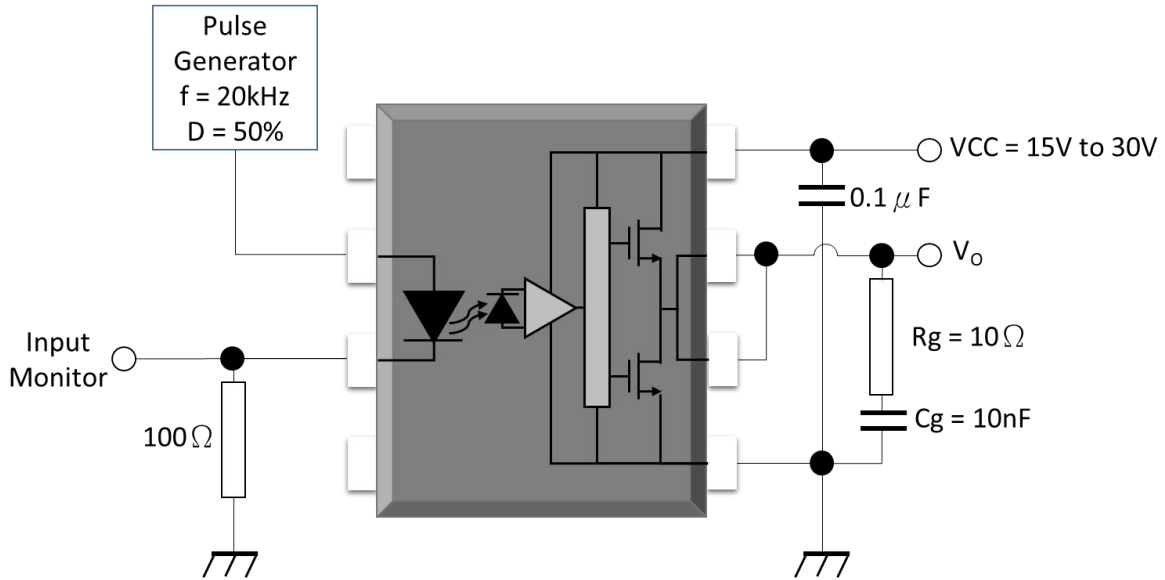
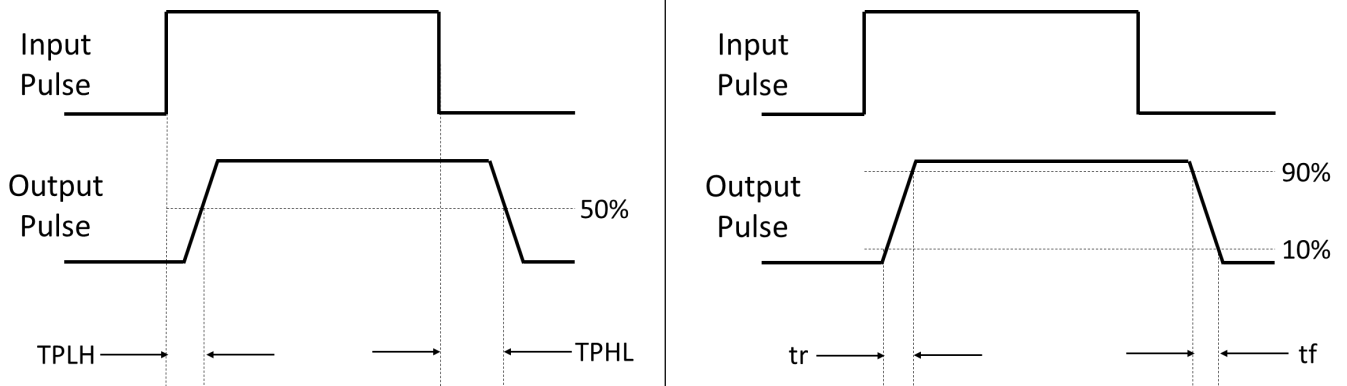

Fig.20 Waveforms of TPHL, TPLH, tr, tf



TEST CIRCUITS

Fig.21 Test Circuits for Common Mode Transient Immunity

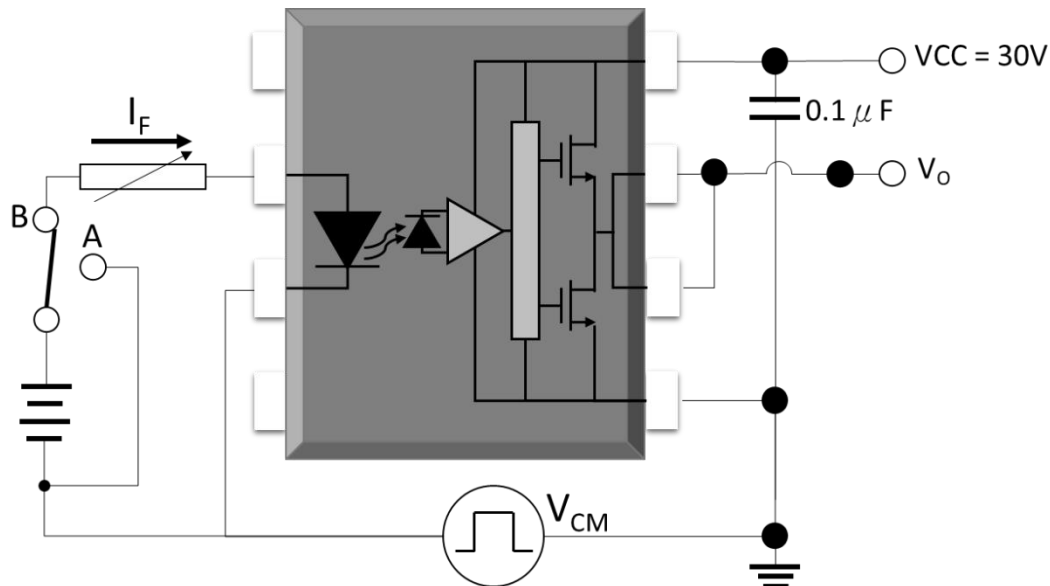
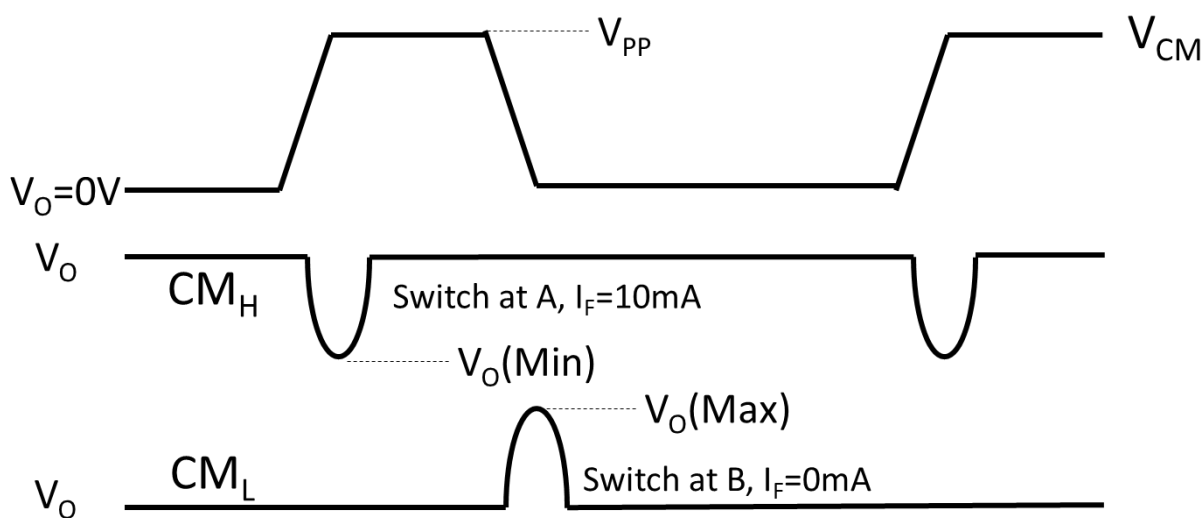
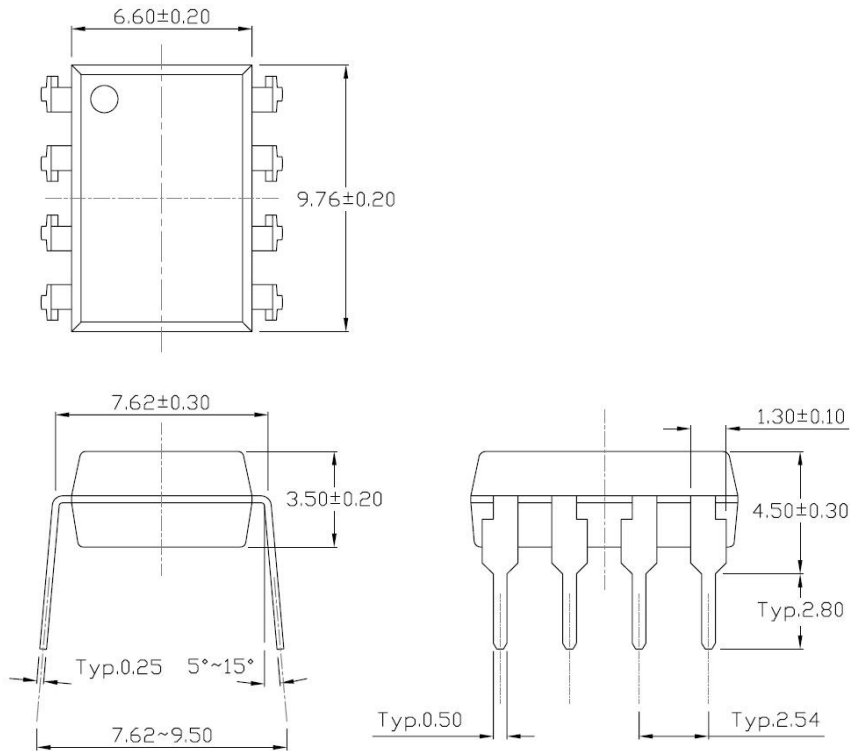

Fig.22 Waveforms of Common Mode Transient Immunity



PACKAGE DIMENSIONS (Dimensions in mm unless otherwise stated)

Standard DIP – Through Hole (DIP Type)



Surface Mount (Low Profile) Lead Forming (SL Type)

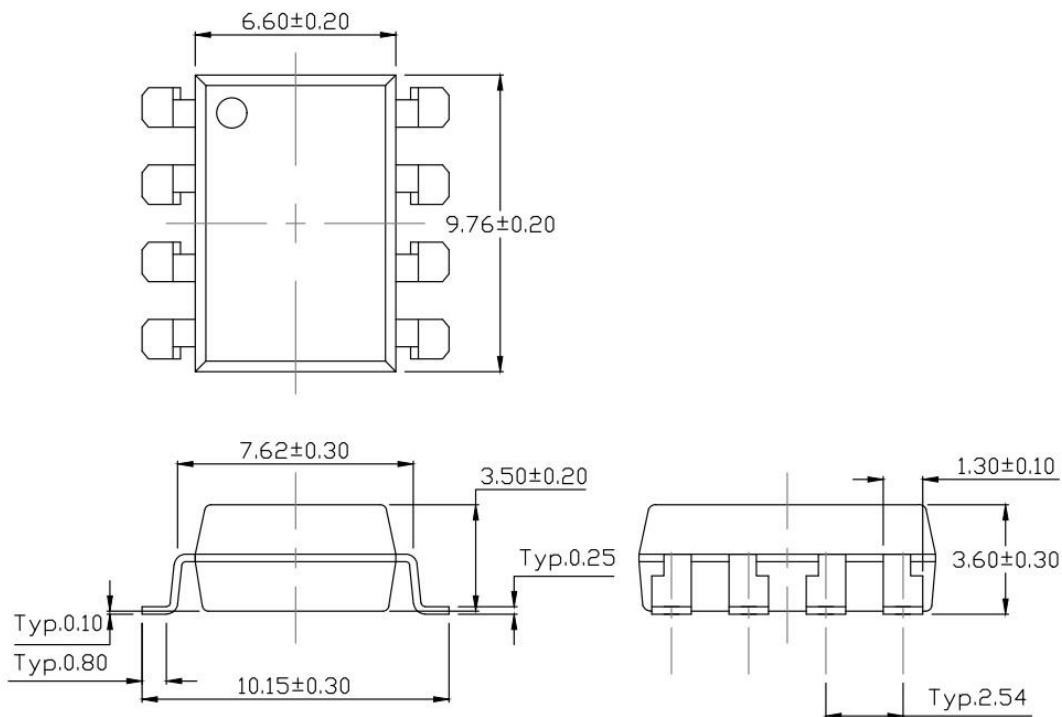

REFLOW INFORMATION

REFLOW PROFILE

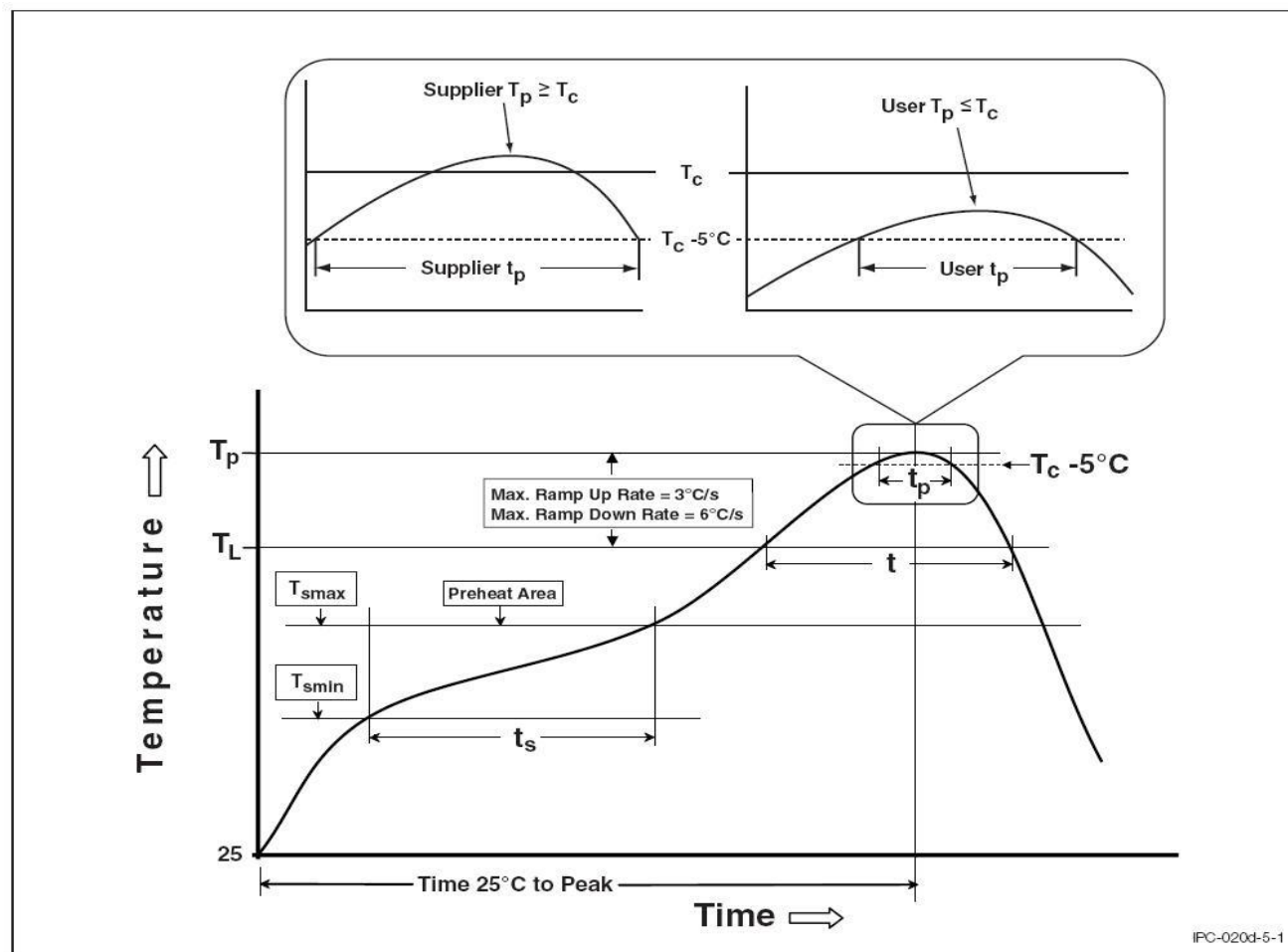

Profile Feature	Sn-Pb Assembly Profile	Pb-Free Assembly Profile
Temperature Min. (T_{smin})	100	150°C
Temperature Max. (T_{smax})	150	200°C
Time (t_s) from (T_{smin} to T_{smax})	60-120 seconds	60-120 seconds
Ramp-up Rate (t_L to t_P)	3°C/second max.	3°C/second max.
Liquidous Temperature (T_L)	183°C	217°C
Time (t_L) Maintained Above (T_L)	60 – 150 seconds	60 – 150 seconds
Peak Body Package Temperature	235°C +0°C / -5°C	260°C +0°C / -5°C
Time (t_P) within 5°C of 260°C	20 seconds	30 seconds
Ramp-down Rate (T_P to T_L)	6°C/second max	6°C/second max
Time 25°C to Peak Temperature	6 minutes max.	8 minutes max.