

注：本板为禁止运输、复制、翻印文件，以及用其内容进行复制或交流

REV	ECN NO.	CONTENT	CHK	DATE
-----	---------	---------	-----	------

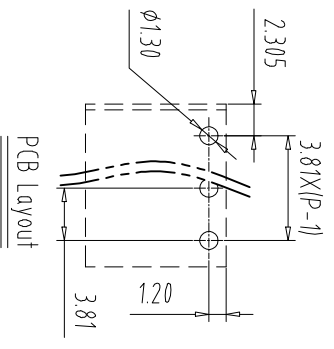
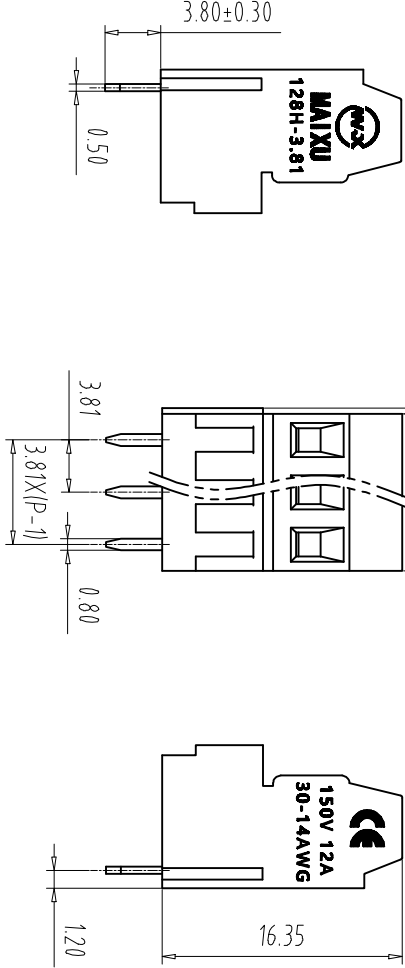
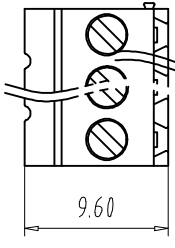

NOTES1:
UL Standard
1.Rating voltage/current: 150V/12A
2.withstanding voltage: AC1600V/1Min
3.Torque value: M2, 1.77Lb.in
4.Wire range: 30~14AWG

IEC Standard

Pollution Degree	3	2	2
Overvoltage Category	III	II	II
Rate Impulse Voltage(KV)	2.5	2.5	2.5
Rate Voltage(V)	160V	200V	400V
Rate Current(A)	10A	10A	10A

2. Torque value: M2, 0.2Nm
3.wire range: 1.0mm²

NOTES2:

- 1.Housing: PA66(UL94V-0)
- 2.Solder Pin: Copper alloy(Sn Plated)
- 3.Cage: Brass(Ni Plated)
- 4.Screw: Steel(M2,Zn Plated)

NOTES3:

- 1.Pitch: 3.81mm Poles: 02-24P
- 2.Stripping length: 5-6mm
- 3.Operating temperature: -40℃~+105℃
- 4.RoHS Compliance

How to order

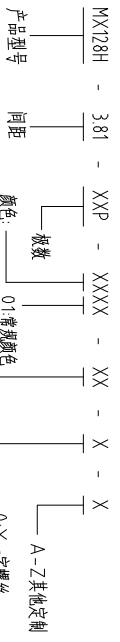

Pitch Range	In mm	Nominal Dimension	Range
Over 6	Over 10	Over 30	Over 60
Over 10	Over 24	Over 60	Over 100
Over 15	Over 30	Over 60	Over 100
Over 20	Over 30	Over 60	Over 100
Over 30	Over 60	Over 100	Over 150

mm	Over 6	Over 10	Over 15	Over 20	Over 30	Over 60	Over 100	Over 150
±0.15	±0.20	±0.30	±0.30	±0.50	±0.70	±1.00	±1.30	±2°

ITEM	NAME OF PART	NO. OF PART	Q'TY	MATERIAL	NOTE
DWG	CHK	DATE	SCALE	SHEET/OF	1/1
APP	DATE	SCALE	NAME		
CIXI MAIXU ELECTRONICS CO.,LTD			MX128H-3.81-XXP		
慈溪市迈旭电子有限公司			DWGNO.		