

NOTES:
1. ALL THE OPERATING PERFORMANCE SPEC. IN BELLOW TABLE SHOULD BE MET. THE MEASURE METHOD IS SHOWN AS FIG.1. OPERATE THE DOME 10 TIMES BEFORE MEASURING.

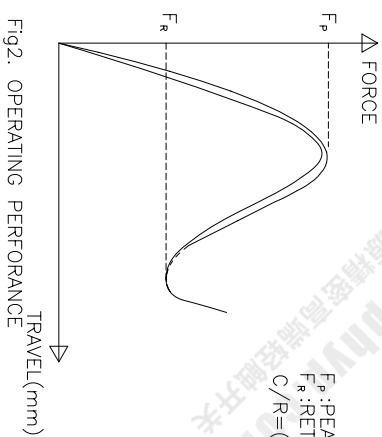
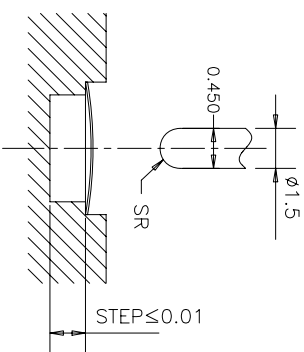

- 1) TEST SPEED : 140 SPM
- 2) TEST FORCE : 1.5*Fp
- 3) MATERIAL : ALUMINUM.
- 4) AFTER LIFE TEST, C/R DECREASE 30% MAX. OBVIOUS BURR, SCRATCHES, CRACKS IS FORBIDDEN.
5. DIMENSIONS MARKED ∇ SHOULD BE CHECKED BY Q.C. AND P.E.
6. HARMFUL MATERIAL CONTROL PLEASE FOLLOW ROHS
6. PART PERFORMANCE TABLE

PART NAME	P.F.(gf)	C/R(%)	MAT'L	FINISH	STEP(mm)
836-0005-***	CP±20	60±15	SUS301	Ag PLATING	0

CP:	H:
100-----80gf	0.32-----80gf
120-----100gf	0.32-----100gf
140-----120gf	0.32-----120gf
160-----140gf	0.35-----140gf
180-----160gf	0.35-----160gf
200-----180gf	0.39-----180gf
230-----200gf	0.39-----200gf
250-----230gf	0.40-----230gf
280-----250gf	0.40-----250gf
280-----280gf	0.40-----280gf

L (mm)	L1 (mm)	L2 (mm)	L3 (mm)	L4
4.06±0.02	4.10±0.10	3.10±0.20	1.30±0.10	1.00±0.10
4.06±0.02	4.10±0.10	3.10±0.20	1.30±0.10	1.00±0.10
4.06±0.02	4.10±0.10	3.10±0.20	1.30±0.10	1.00±0.10
4.06±0.02	4.10±0.10	3.10±0.20	1.30±0.10	1.00±0.10

X. ± 0.2	X' ± 0.2'	UNITS	MM	NAME(INTENDED USE)	HON YUAN
X ± 0.1	X' ± 0.1'	MAT'L		METAL DOME FOR TACT SWITCH	HON YUAN PRECISION IND. CO.,LTD. SHENZHEN, CHINA, R.O.C.
.XX ± 0.05	.XX' ± 0.01'	FINISH		PART NO.(INTENDED USE)	TITLE: CUSTOMER DRAWING
.XXX ± 0.03	.XXX' ± 0.005'			N/A	DWG NO.: 836-0000-000
<small>THESE DRAWINGS AND SPECIFICATIONS ARE THE PROPERTY OF HON YUAN PRECISION IND. CO., LTD. AND SHALL NOT BE REPRODUCED, COPIED OR USED IN ANY MANNER WITHOUT THE PRIOR WRITTEN CONSENT OF HON YUAN PRECISION IND. CO., LTD.</small>				Q'TY	
				CHKD: P910J0M 06/06'15	SCALE SHEET REV.
				DR: M.H.L.L 06/06'15	1/1 1/1 C