

## Current Mode PWM Controller for Forward and Flyback Applications

### General Description

The NCP1252 controller offers everything needed to build cost-effective and reliable ac-dc switching supplies dedicated to ATX power supplies. Thanks to the use of an internally fixed timer, NCP1252 detects an output overload without relying on the auxiliary Vcc. A Brown-Out input offers protection against low input voltages and improves the converter safety. Finally a SOP8 package saves PCB space and represents a solution of choice in cost sensitive project.

### Features

- Peak Current Mode Control
- Adjustable Switching Frequency up to 500 kHz
- Jittering Frequency  $\pm 5\%$  of the Switching Frequency
- Latched Primary Over Current Protection with 10 ms Fixed Delay
- Delayed Operation Upon Start-up via an Internal Fixed Timer
- Adjustable Soft-start Timer
- Auto-recovery Brown-Out Detection
- UC384X-like UVLO Thresholds
- Vcc Range from 9 V to 28 V with Auto-recovery UVLO
- Internal 160 ns Leading Edge Blanking
- Adjustable Internal Ramp Compensation
- +500 mA / -800 mA Source / Sink Capability
- Maximum 50% Duty Cycle: A Version
- Ready for Updated No Load Regulation Specifications
- SOP8, MSOP8 and DIP8 Packages
- These are Pb-Free Devices

### Ordering Information

DEVICE	Package Type	MARKING	Packing	Packing Qty
NCP1252PG	DIP8	NCP1252	TUBE	2000pcs/box
NCP1252DRG	SOP8	NCP1252	REEL	2500pcs/reel
NCP1252DGKRG	MSOP8	P1252	REEL	3000pcs/reel

**Typical Applications**

- Power Supplies for PC Silver Boxes, Games Adapter...
- Flyback and Forward Converter

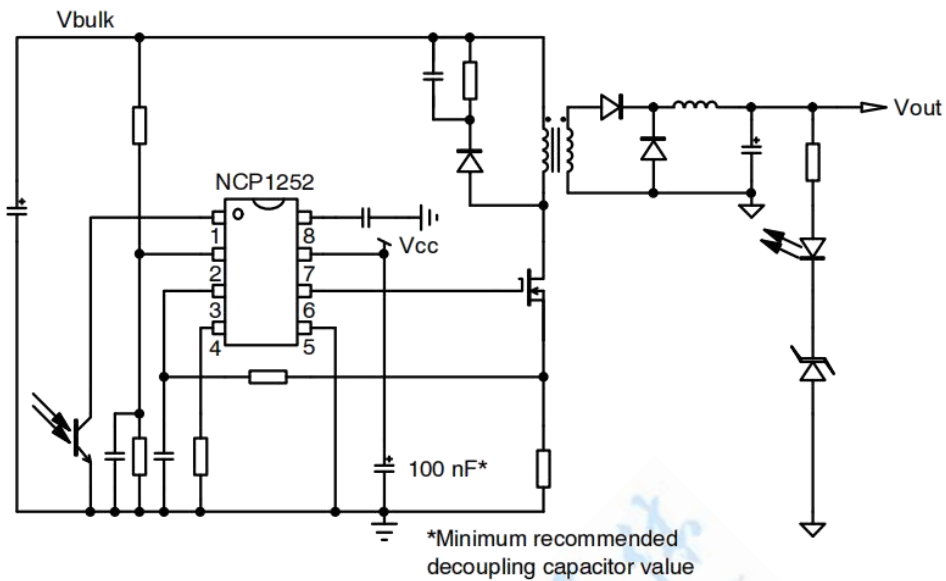
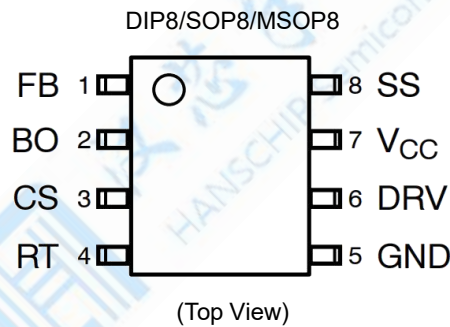


Figure 1. Typical Application

**PIN CONNECTIONS**

**Table 1. PIN FUNCTIONS**

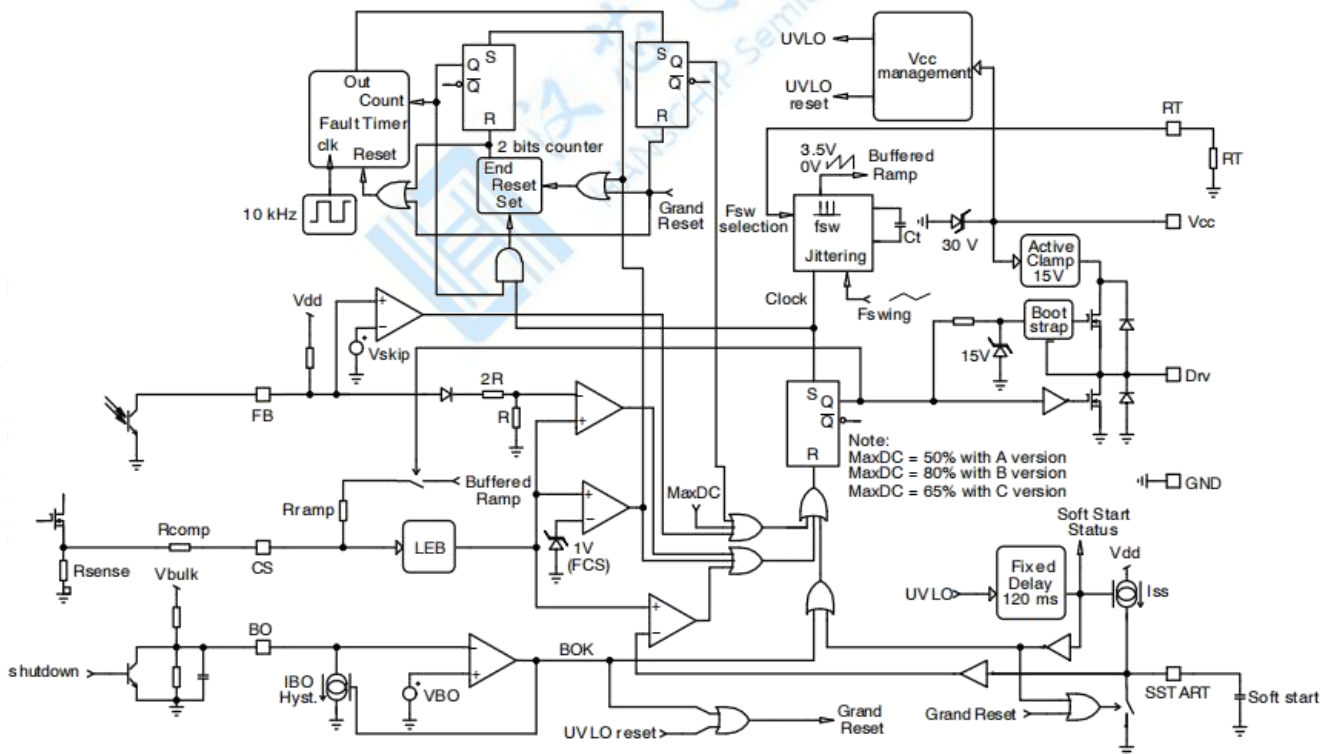
Pin No.	Pin Name	Function	Pin Description
1	FB	Feedback	This pin directly connects to an optocoupler collector.
2	BO	Brown-out input	This pin monitors the input voltage image to offer a Brown-out protection.
3	CS	Current sense	Monitors the primary current and allows the selection of the ramp compensation amplitude.
4	RT	Timing element	A resistor connected to ground fixes the switching frequency.
5	GND	-	The controller ground pin.
6	Drv	Driver	This pin connects to the MOSFET gate
7	V <sub>CC</sub>	V <sub>CC</sub>	This pin accepts voltage range from 8 V up to 28 V
8	SSTART	Soft-start	A capacitor connected to ground selects the soft-start duration. The softstart is grounded during the delay timer

**Table 2. MAXIMUM RATINGS TABLE** (Notes 1 and 2)

Symbol	Rating	Value	Unit
V <sub>CC</sub>	Power Supply voltage, V <sub>cc</sub> pin, transient voltage: 10 ms with I <sub>VCC</sub> < 20 mA	30	V
V <sub>CC</sub>	Power Supply voltage, V <sub>cc</sub> pin, continuous voltage	28	V
I <sub>VCC</sub>	Maximum current injected into pin 7	20	mA
	Maximum voltage on low power pins (except pin 6, 7)	-0.3 to 10	V
R <sub>θJA</sub> – PDIP8	Thermal Resistance Junction-to-Air – DIP	131	°C/W
R <sub>θJA</sub> – SOIC8	Thermal Resistance Junction-to-Air – SOP	169	°C/W
T <sub>JMAX</sub>	Maximum Junction Temperature	150	°C
	Storage Temperature Range	-60 to +150	°C
	ESD Capability, HBM model	1.8	kV
	ESD Capability, Machine Model	200	V

Stresses exceeding Maximum Ratings may damage the device. Maximum Ratings are stress ratings only. Functional operation above the Recommended Operating Conditions is not implied. Extended exposure to stresses above the Recommended Operating Conditions may affect device reliability.

1. This device series contains ESD protection and exceeds the following tests: Human Body Model 1800 V per JEDEC Standard JESD22-A114E. Machine Model Method 200 V per JEDEC Standard JESD22-A115A.
2. This device contains latch-up protection and exceeds 100 mA per JEDEC Standard JESD78.


**Figure 2. Internal Circuit Architecture**

**Table 3. ELECTRICAL CHARACTERISTICS**

 (V<sub>CC</sub> = 15 V, R<sub>T</sub> = 43 kΩ, C<sub>DRV</sub> = 1 nF. For typical values T<sub>J</sub> = 25°C, for min/max values T<sub>J</sub> = -25°C to +125°C, unless otherwise noted)

Characteristics	Test Condition	Symbol	Min	Typ	Max	Unit
Startup threshold at which driving pulses are authorized	V <sub>CC</sub> increasing	V <sub>CC(on)</sub>	9.4	10	10.6	V
Minimum Operating voltage at which driving pulses are stopped	V <sub>CC</sub> decreasing	V <sub>CC(off)</sub>	8.4	9	9.6	V
Hysteresis between V <sub>CC(on)</sub> and V <sub>CC(min)</sub>		V <sub>CC(HYS)</sub>	0.9	1.0	-	V
Start-up current, controller disabled	V <sub>CC</sub> < V <sub>CC(on)</sub> & V <sub>CC</sub> increasing from zero	I <sub>CC1</sub>	-	-	100	μA
Internal IC consumption, controller switching	F <sub>sw</sub> = 100 kHz, DRV = open	I <sub>CC2</sub>	0.5	1.4	2.2	mA
Internal IC consumption, controller switching	F <sub>sw</sub> = 100 kHz, C <sub>DRV</sub> = 1 nF	I <sub>CC3</sub>	2.0	2.7	3.5	mA
<b>CURRENT COMPARATOR</b>						
Current Sense Voltage Threshold		V <sub>ILIM</sub>	0.92	1	1.08	V
Leading Edge Blanking Duration		t <sub>LEB</sub>	-	160	-	ns
Input Bias Current	(Note 3)	I <sub>bias</sub>	-	0.02	-	μA
Propagation delay	From CS detected to gate turned off	t <sub>LIM</sub>	-	70	150	ns
Internal Ramp Compensation Voltage level	@ 25°C (Note 4)	V <sub>ramp</sub>	3.15	3.5	3.85	V
Internal Ramp Compensation resistance to CS pin	@ 25°C (Note 4)	R <sub>ramp</sub>	-	26.5	-	kΩ
<b>INTERNAL OSCILLATOR</b>						
Oscillator Frequency	R <sub>T</sub> = 43 kΩ & DRV pin = 47 kΩ	f <sub>OSC</sub>	92	100	108	kHz
Oscillator Frequency	R <sub>T</sub> = 8.5 kΩ & DRV pin = 47 kΩ	f <sub>OSC</sub>	425	500	550	kHz
Frequency Modulation in percentage of f <sub>OSC</sub>	(Note 3)	f <sub>jitter</sub>	-	5	-	%
Frequency modulation Period	(Note 3)	T <sub>swing</sub>	-	3.33	-	ms
Maximum operating frequency	(Note 3)	f <sub>MAX</sub>	500	-	-	kHz
Maximum duty-cycle – A version		DC <sub>maxA</sub>	45.6	48	49.6	%
<b>FEEDBACK SECTION</b>						
Internal voltage division from FB to CS setpoint		FB <sub>div</sub>	-	3	-	-
Internal pull-up resistor		R <sub>pull-up</sub>	-	3.5	-	kΩ
FB pin maximum current	FB pin = GND	I <sub>FB</sub>	1.5	-	-	mA
Internal feedback impedance from FB to GND		Z <sub>FB</sub>	-	40	-	kΩ
Open loop feedback voltage	FB pin = open	V <sub>FBOL</sub>	-	6.0	-	V
Internal Diode forward voltage	(Note 3)	V <sub>f</sub>	-	0.75	-	V
<b>DRIVE OUTPUT</b>						
DRV Source resistance		R <sub>SRC</sub>	-	10	30	Ω
DRV Sink resistance		R <sub>SINK</sub>	-	6	19	Ω
Output voltage rise-time	V <sub>CC</sub> = 15 V, C <sub>DRV</sub> = 1 nF, 10 to 90%	t <sub>r</sub>	-	26	-	ns
Output voltage fall-time	V <sub>CC</sub> = 15 V, C <sub>DRV</sub> = 1 nF, 90 to 10%	t <sub>f</sub>	-	22	-	ns
Clamping voltage (maximum gate voltage)	V <sub>CC</sub> = 25 V R <sub>DRV</sub> = 47 kΩ, C <sub>DRV</sub> = 1 nF	V <sub>CL</sub>	-	15	18	V
High-state voltage drop	V <sub>CC</sub> = V <sub>CC(min)</sub> + 100 mV, R <sub>DRV</sub> = 47 kΩ, C <sub>DRV</sub> = 1 nF	V <sub>DRV(clamp)</sub>	-	50	500	mV

3. Guaranteed by design
4. V<sub>ramp</sub>, R<sub>ramp</sub> Guaranteed by design

**Table 3. ELECTRICAL CHARACTERISTICS**(continued)

 $(V_{CC} = 15\text{ V}, R_T = 43\text{ k}\Omega, C_{DRV} = 1\text{ nF})$ . For typical values  $T_J = 25^\circ\text{C}$ , for min/max values  $T_J = -25^\circ\text{C}$  to  $+125^\circ\text{C}$ , unless otherwise noted)

Characteristics	Test Condition	Symbol	Min	Typ	Max	Unit
<b>CYCLE SKIP</b>						
Skip cycle level		$V_{skip}$	0.2	0.3	0.4	V
Skip threshold Reset		$V_{skip(reset)}$	-	$V_{skip}^+$ $V_{skip(HYS)}$	-	V
Skip threshold Hysteresis		$V_{skip(HYS)}$	-	25	-	mV
<b>SOFT START</b>						
Soft-start charge current	SS pin = GND	$I_{SS}$	8.8	10	11	$\mu\text{A}$
Soft start completion voltage threshold		$V_{SS}$	3.5	4.0	4.5	V
Internal delay before starting the Soft start when $V_{CC(on)}$ is reached		$SS_{delay}$	100	120	155	ms
<b>PROTECTION</b>						
Current sense fault voltage level triggering the timer		FCS	0.9	1	1.1	V
Timer delay before latching a fault (overload or short circuit)	When CS pin > FCS	$T_{fault}$	10	15	20	ms
Brown-out voltage		$V_{BO}$	0.974	1	1.026	V
Internal current source generating the Brown-out hysteresis	$-5^\circ\text{C} \leq T_J \leq +125^\circ\text{C}$ $-25^\circ\text{C} \leq T_J \leq +125^\circ\text{C}$	$I_{BO}$	8.8 8.6	10 10	11.2 11.2	$\mu\text{A}$

3. Guaranteed by design
4.  $V_{ramp}, R_{ramp}$  Guaranteed by design

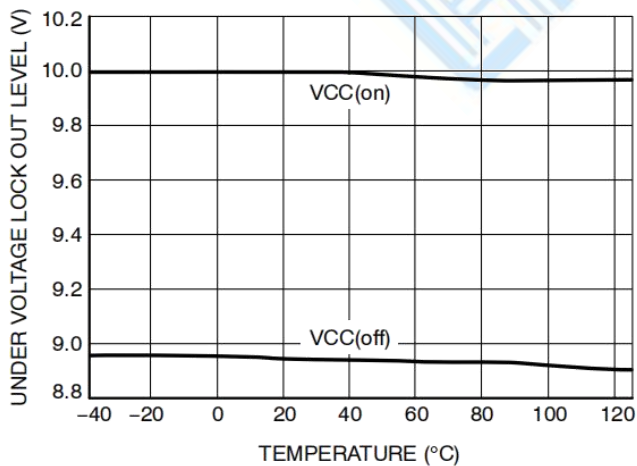
**TYPICAL CHARACTERISTICS**


Figure 3. Supply Voltage Threshold vs. Junction Temperature

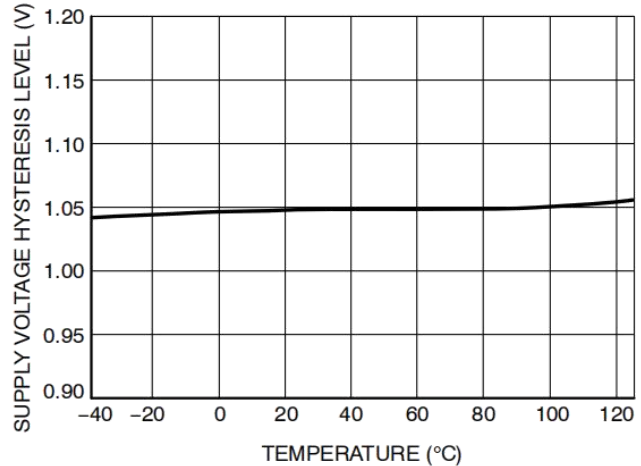


Figure 4. Supply Voltage Hysteresis vs. Junction Temperature

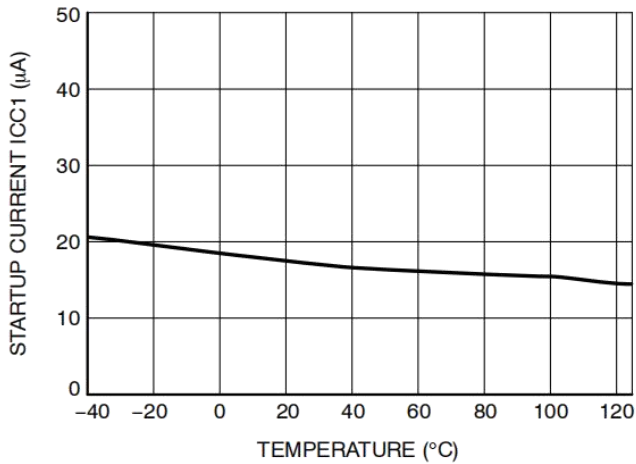
**TYPICAL CHARACTERISTICS**


Figure 5. Start-up Current (ICC1) vs. Junction Temperature

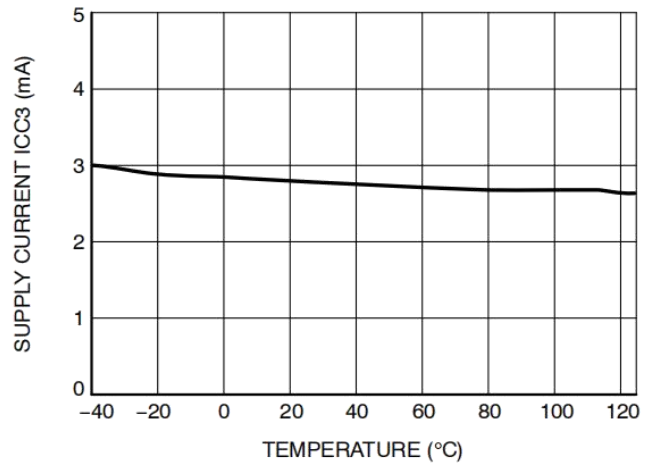


Figure 6. Supply Current (ICC3) vs. Junction Temperature

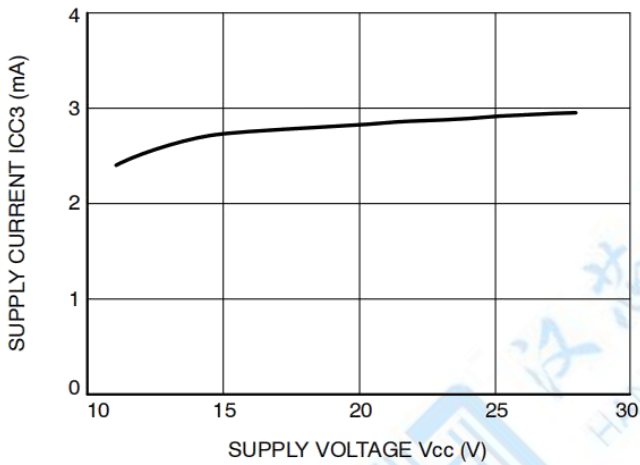


Figure 7. Supply Current (ICC3) vs. Supply Voltage

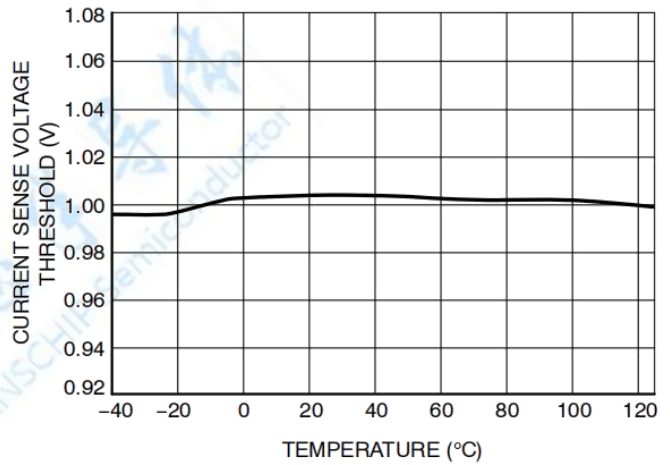


Figure 8. Current Sense Voltage Threshold vs. Junction Temperature

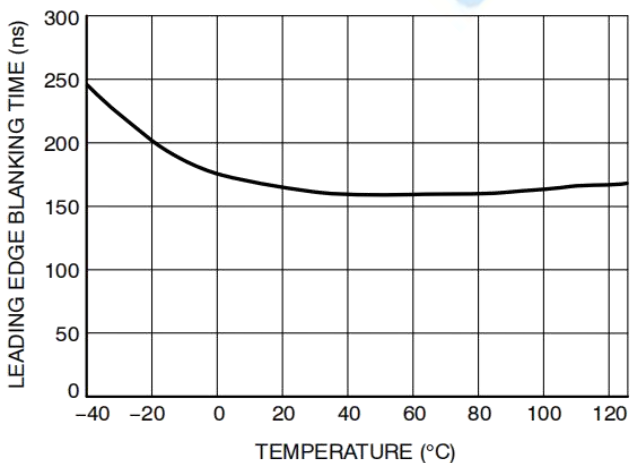


Figure 9. Leading Edge Blanking Time vs. Junction Temperature

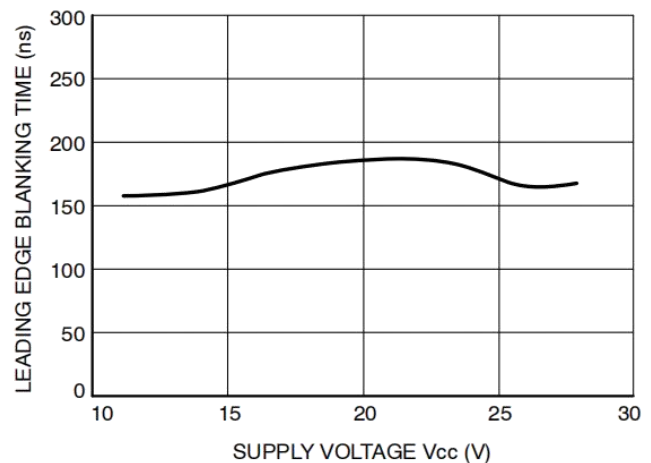


Figure 10. Leading Edge Blanking Time vs. Supply Voltage

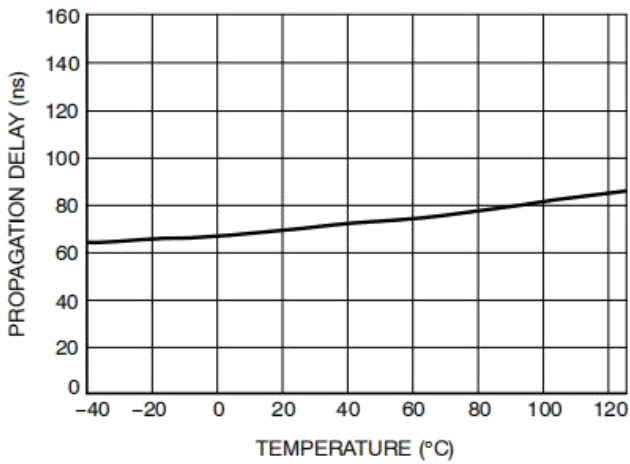
**TYPICAL CHARACTERISTICS**


Figure 11. Propagation Delay from CS to DRV vs. Junction Temperature

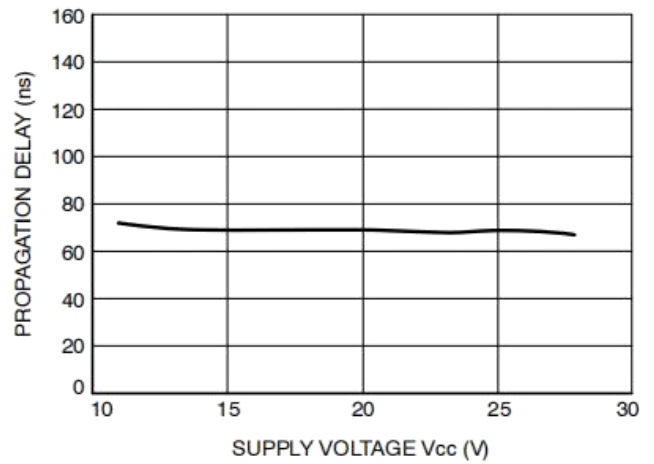


Figure 12. Propagation Delay from CS to DRV vs. Supply Voltage

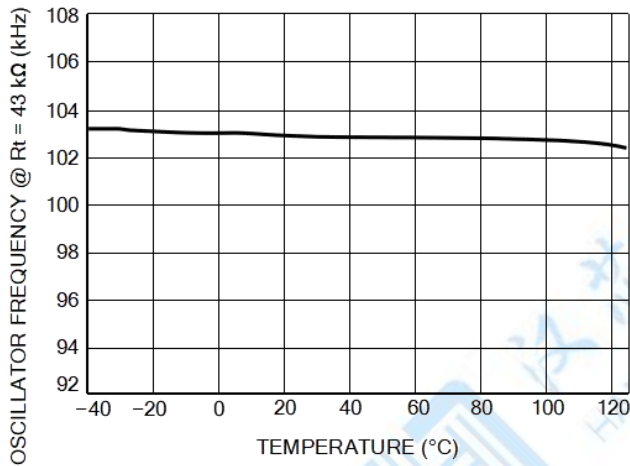


Figure 13. Oscillator Frequency vs. Junction Temperature

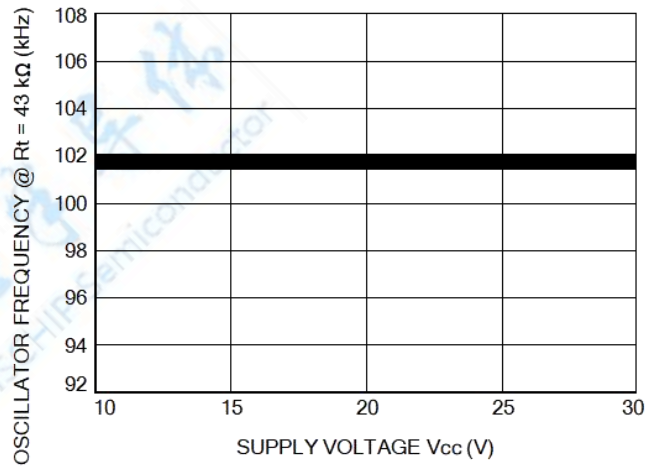


Figure 14. Oscillator Frequency vs. Supply Voltage

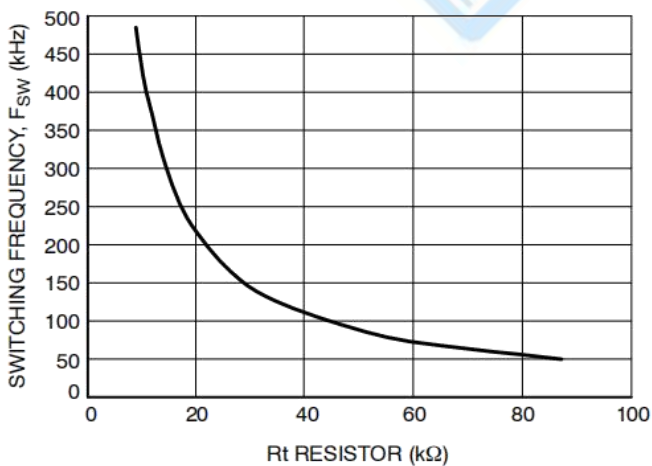


Figure 15. Oscillator Frequency vs. Oscillator Resistor

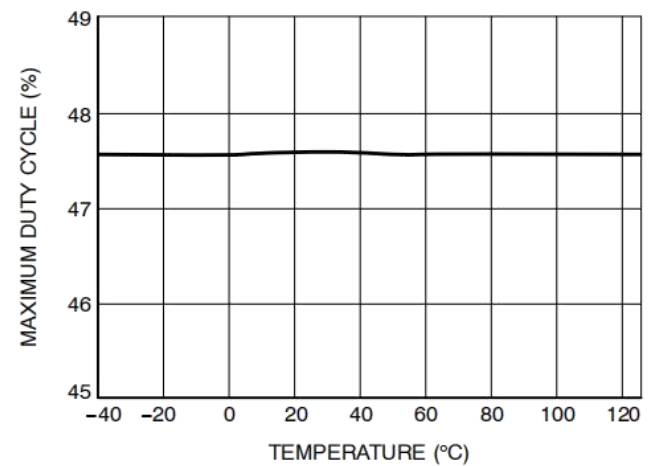


Figure 16. Maximum Duty-cycle, A Version vs. Junction Temperature

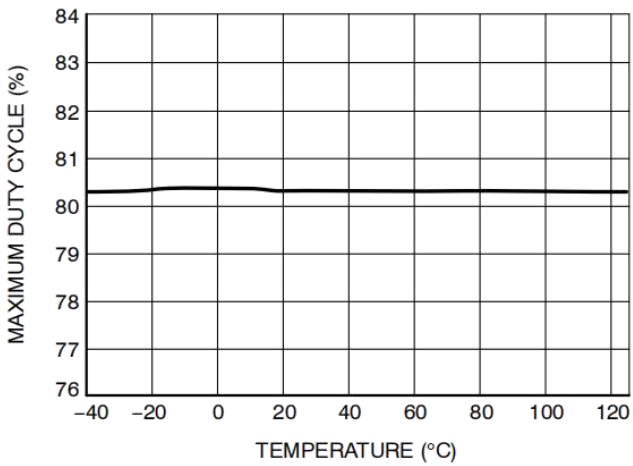
**TYPICAL CHARACTERISTICS**


Figure 17. Maximum Duty-cycle, B Version vs. Junction Temperature

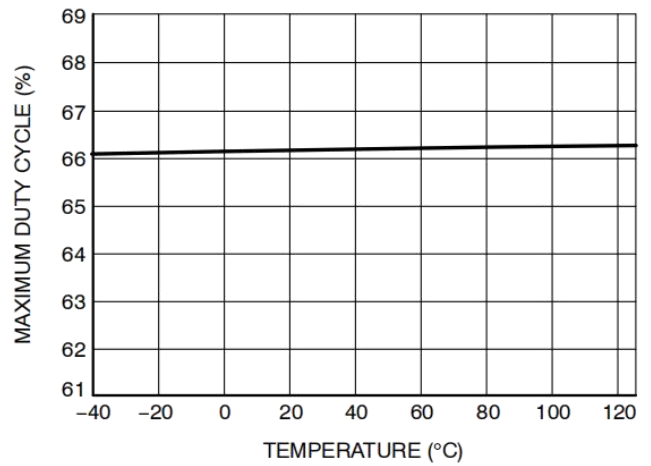


Figure 18. Maximum Duty-cycle, C Version vs. Junction Temperature

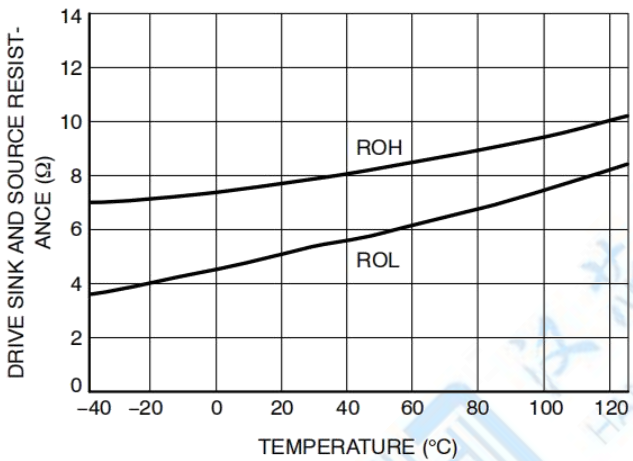


Figure 19. Drive Sink and Source Resistances vs. Junction Temperature

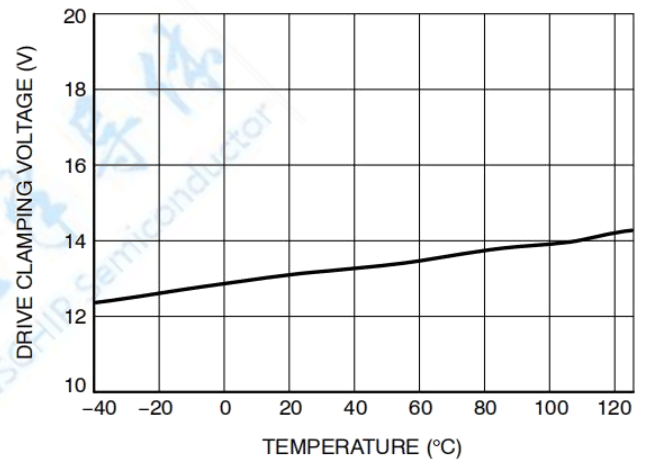


Figure 20. Drive Clamping Voltage vs. Junction Temperature

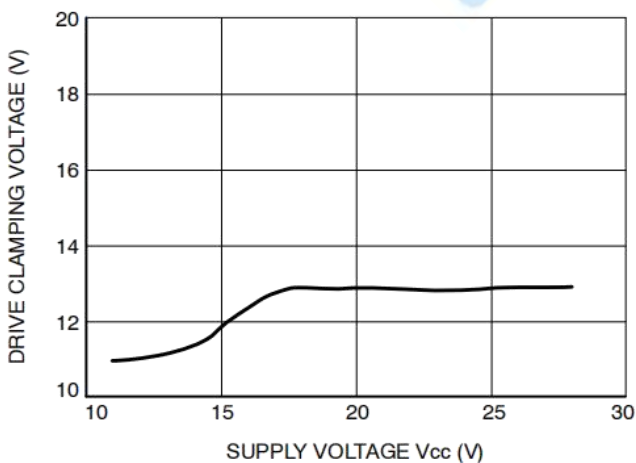


Figure 21. Drive Clamping Voltage vs. Supply Voltage

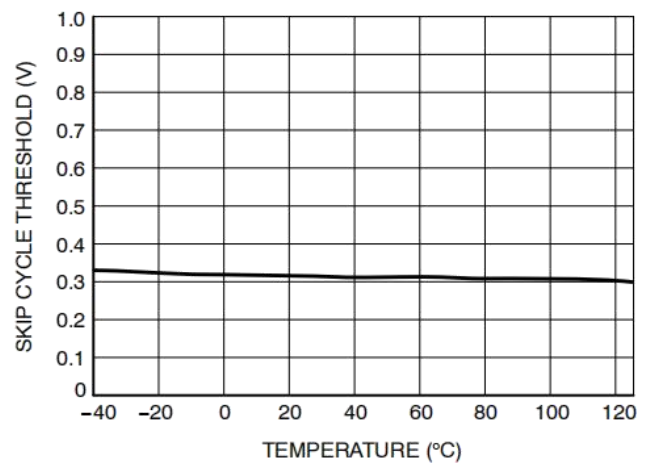


Figure 22. Skip Cycle Threshold vs. Junction Temperature



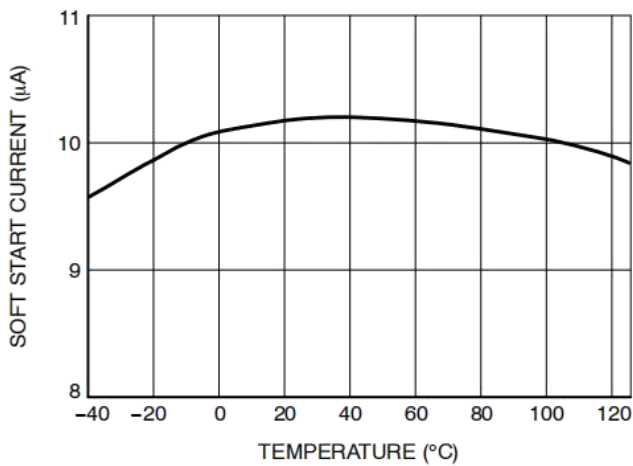
**TYPICAL CHARACTERISTICS**


Figure 23. Soft Start Current vs. Junction Temperature

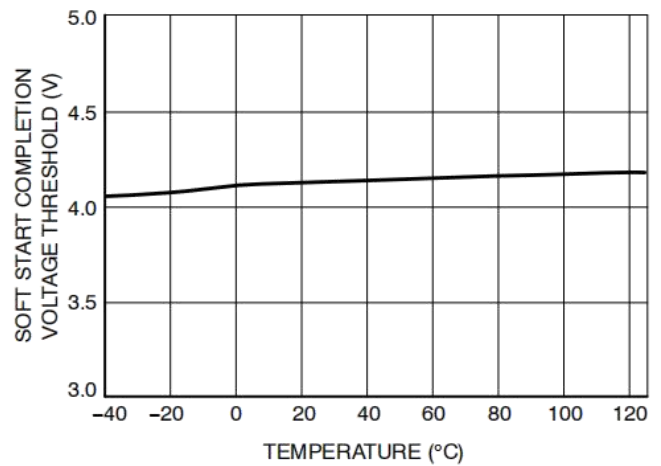


Figure 24. Soft Start Completion Voltage Threshold vs. Junction Temperature

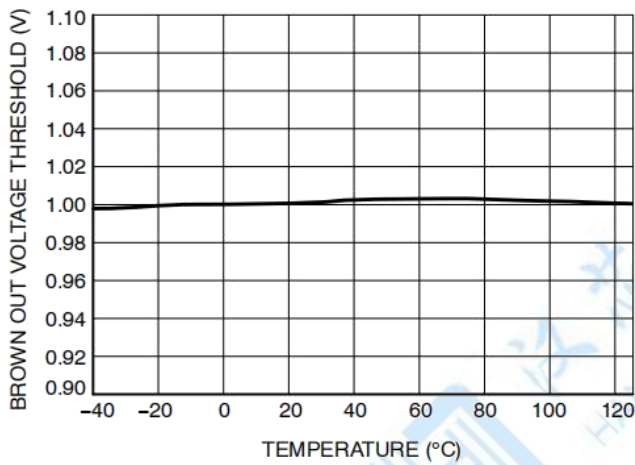


Figure 25. Brown Out Voltage Threshold vs. Junction Temperature

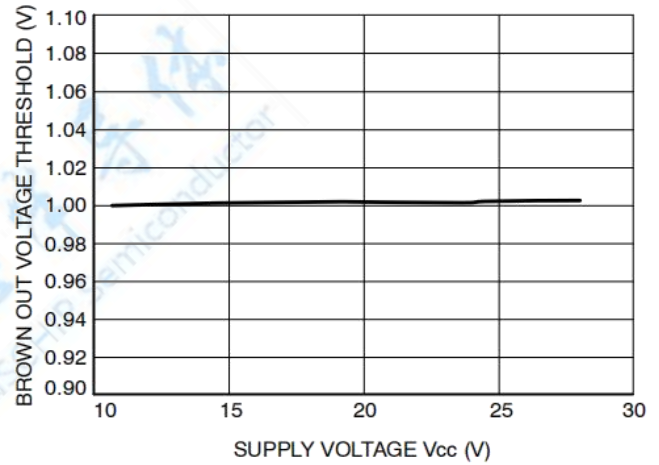


Figure 26. Brown Out Voltage Threshold vs. Supply Voltage

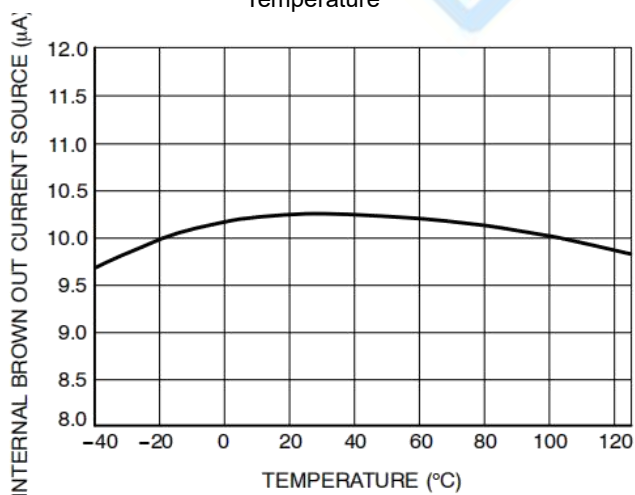


Figure 27. Internal Brown Out Current Source vs. Junction Temperature

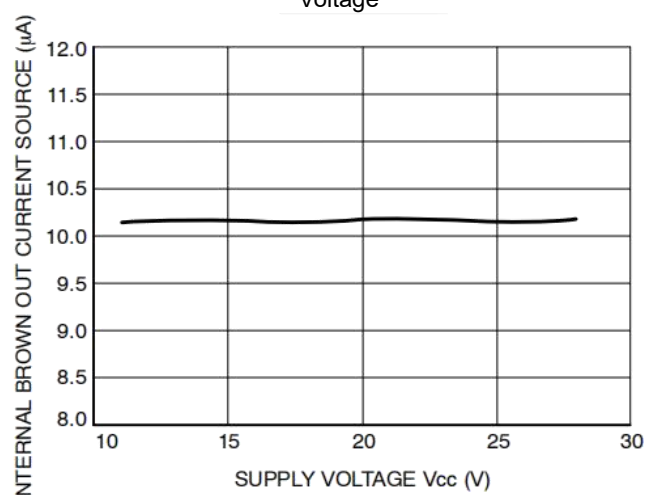


Figure 28. Internal Brown Out Current Source vs. Supply Voltage

## Application Information

### Introduction

The NCP1252 hosts a high-performance current-mode controller specifically developed to drive power supplies designed for the ATX and the adapter market:

- **Current Mode operation:** implementing peak current-mode control topology, the circuit offers UC384X-like features to build rugged power supplies.
- **Adjustable switching frequency:** a resistor to ground precisely sets the switching frequency between 50 kHz and a maximum of 500 kHz. There is no synchronization capability.
- **Internal frequency jittering:** Frequency jittering softens the EMI signature by spreading out peak energy within a band  $\pm 5\%$  from the center frequency.
- **Wide Vcc excursion:** the controller allows operation up to 28 V continuously and accepts transient voltage up to 30 V during 10 ms with  $I_{VCC} < 20$  mA
- **Gate drive clamping:** a lot of power MOSFETs do not allow their driving voltage to exceed 20 V. The controller includes a low-loss clamping voltage which prevents the gate from going beyond 15 V typical.
- **Low startup-current:** reaching a low no-load standby power represents a difficult exercise when the controller requires an external, lossy, resistor connected to the bulk capacitor. The start-up current is guaranteed to be less than 100  $\mu$ A maximum, helping the designer to reach a low standby power level.
- **Short-circuit protection:** by monitoring the CS pin voltage when it exceeds 1 V (maximum peak current), the controller detects a fault and starts an internal digital timer. On the condition that the digital timer elapses, the controller will permanently latch-off. This allows accurate overload or short-circuit detection which is not dependant on the auxiliary winding. Reset occurs when: a) a BO reset is sensed, b) VCC is cycled down to VCC(min) level. If the short circuit or the fault disappear before the fault timer ends, the fault timer is reset only if the CS pin voltage level is below 1 V at least during 3 switching frequency periods. This delay before resetting the fault timer prevents any false or missing fault or over load detection.
- **Adjustable soft-start:** the soft-start is activated upon a start-up sequence (VCC going-up and crossing VCC(on)) after a minimum internal time delay of 120 ms (SSdelay). But also when the brown-out pin is reset without in that case timer delay. This internal time delay gives extra time to the PFC to be sure that the output PFC voltage is in regulation. The soft start pin is grounded until the internal delay is ended.
- **Shutdown:** if an external transistor brings the BO pin down, the controller is shut down, but all internal biasing circuits are alive. When the pin is released, a new soft-start sequence takes place.
- **Brown-Out protection:** BO pin permanently monitors a fraction of the input voltage. When this image is below the VBO threshold, the circuit stays off and does not switch. As soon the voltage image comes back within safe limits, the pulses are re-started via a start-up sequence including soft-start. The hysteresis is implemented via a current source connected to the BO pin; this current source sinks a current (IBO) from the pin to the ground. As the current source status depends on the brown-out comparator, it can easily be used for hysteresis purposes. A transistor pulling down the BO pin to ground will shut-off the controller. Upon release, a new soft-start sequence takes place.
- **Internal ramp compensation:** a simple resistor connected from the CS pin to the sense resistor allows the designer to inject ramp compensation inside his design.
- **Skip cycle feature:** When the power supply loads are decreasing to a low level, the duty cycle also decreases to the minimum value the controller can offer. If the output loads disappear, the converter runs at the minimum duty cycle fixed by the propagation delay and driving blocks. It often delivers too much energy to the secondary side and it trips the voltage supervisor. To avoid this problem, the FB is allowed to impose the min tON down to  $\sim V_f$  and it further decreases down to  $V_{skip}$ , zero duty cycle is imposed. This mode helps to ensure no-load outputs conditions as requested by recently updated ATX specifications. Please note that the converter first goes to min tON before going to zero duty cycle: normal operation is thus not disturbed. The following figure illustrates the different mode of operation versus the FB pin level.

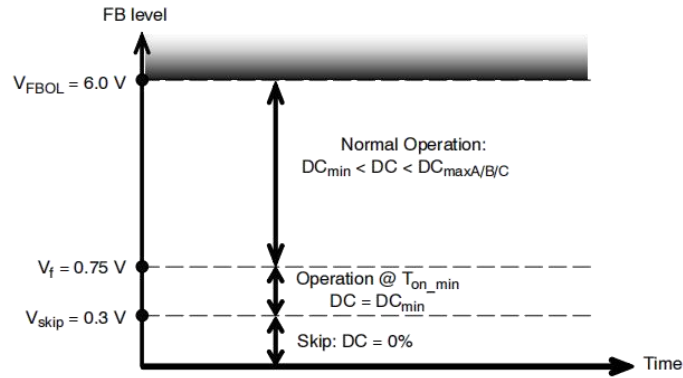


Figure 29. Mode of Operation versus the FB Pin Level

### Startup Sequence:

The startup sequence is activated when V<sub>CC</sub> pin reaches V<sub>CC(on)</sub> level. Once the startup sequence has been activated the internal delay timer (SSdelay) runs. Only when the internal delay elapses the soft start can be allowed if the BO pin level is above V<sub>BO</sub> level. If the BO pin threshold is reached or as soon as this level will be reached the soft start is allowed. When the soft start is allowed the SS pin is released from the ground and the current source connected to this pin sources its current to the external capacitor connected on SS pin. The voltage variation of the SS pin divided by 4 gives the same peak current variation on the CS pin.

The following figures illustrate the different startup cases.

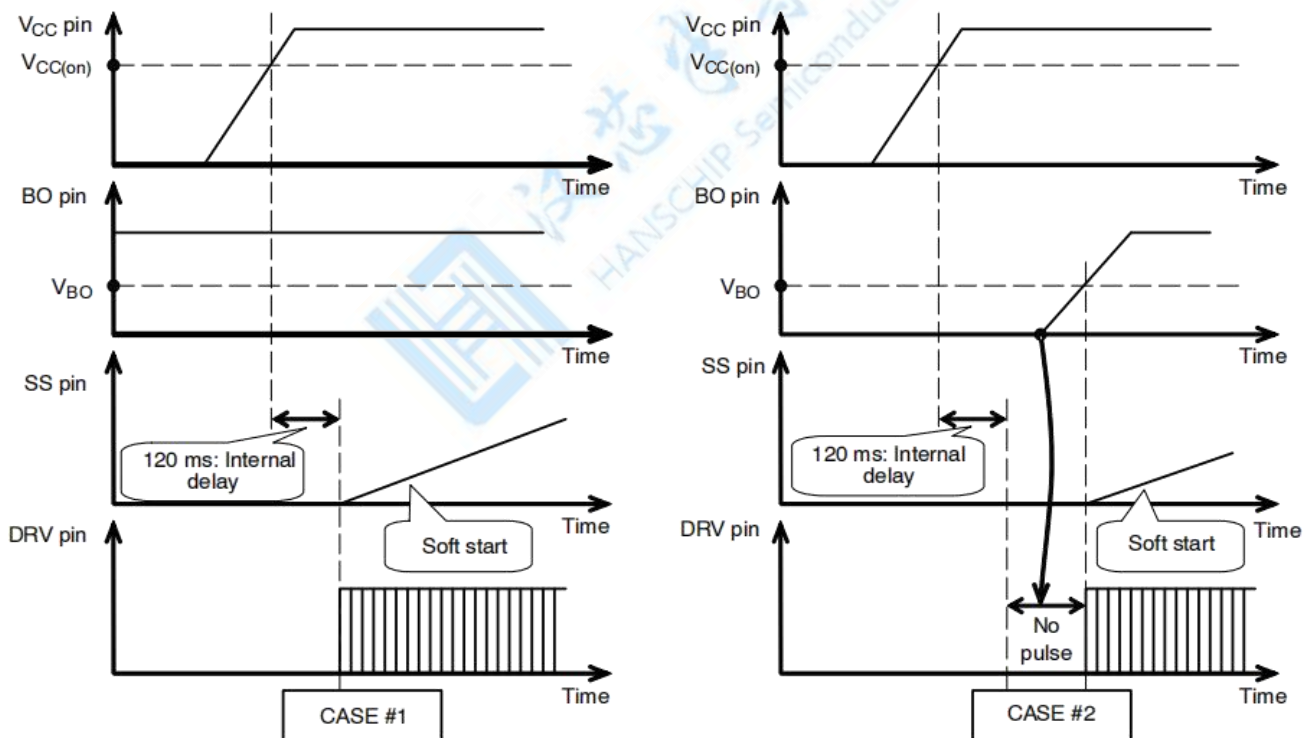


Figure 30. Different Startup Sequence Case #1 & #2

With the Case #1, when the V<sub>CC</sub> pin reaches the V<sub>CC(on)</sub> level, the internal timer starts. As the BO pin level is above the V<sub>BO</sub> threshold at the end of the internal delay, a soft start sequence is started.

With the Case #2, at the end of the internal delay, the BO pin level is below the V<sub>BO</sub> threshold thus the soft start sequence can not start. A new soft start sequence will start only when the BO pin reaches the V<sub>BO</sub> threshold.

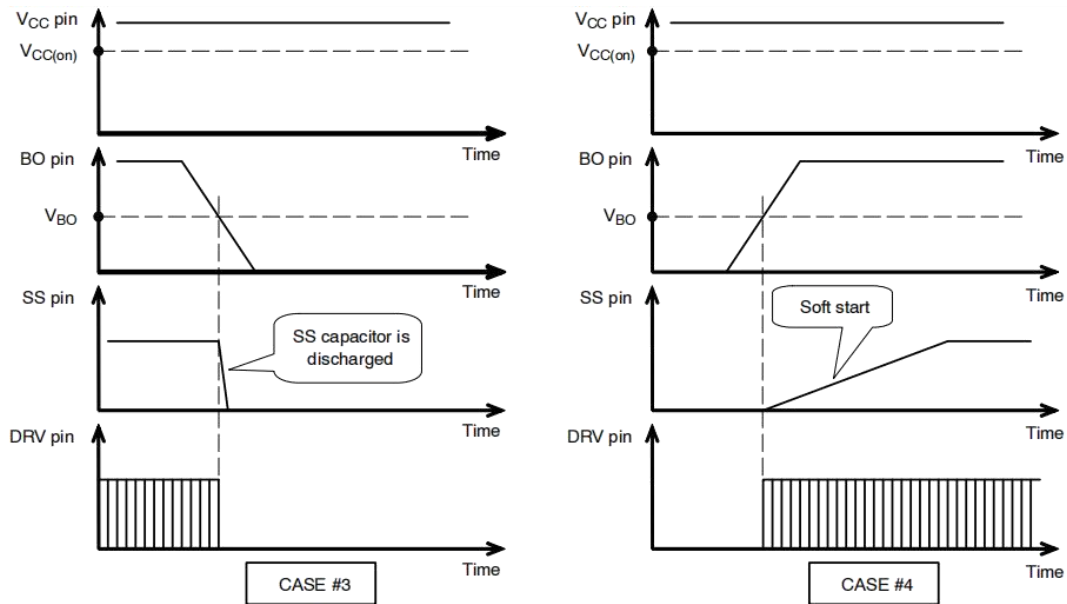


Figure 31. Controller Shuts Down with the Brown Out Pin

When the BO pin is grounded, the controller is shut down and the SS pin is internally grounded in order to discharge the soft start capacitor connected to this pin (Case #3). If the BO pin is released, when its level reaches the  $V_{BO}$  level a new soft start sequence happens.

**Soft Start:**

As illustrated by the following figure, the rising voltage on the SS pin voltage divided by 4 controls the peak current sensed on the CS pin. Thus as soon as the CS pin voltage becomes higher than the SS pin voltage divided by 4 the driver latch is reset.

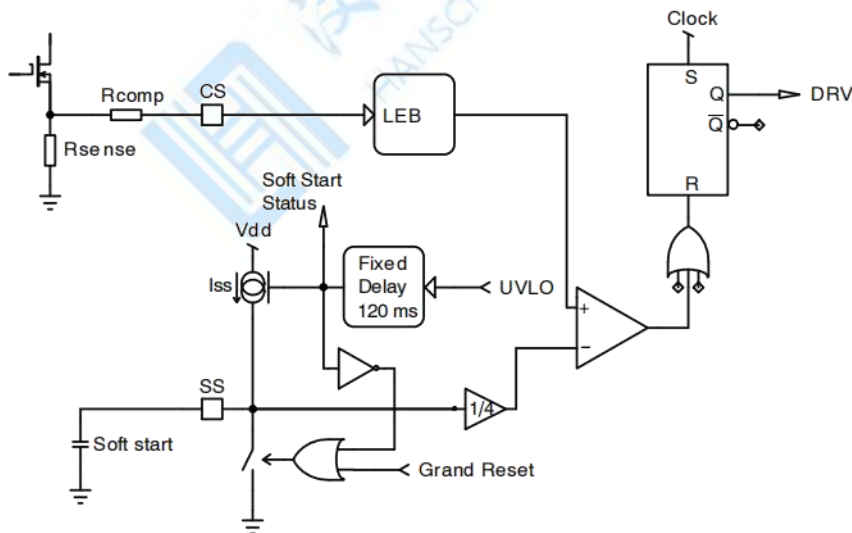


Figure 32. Soft Start Principle

The following figure illustrates a soft start sequence.

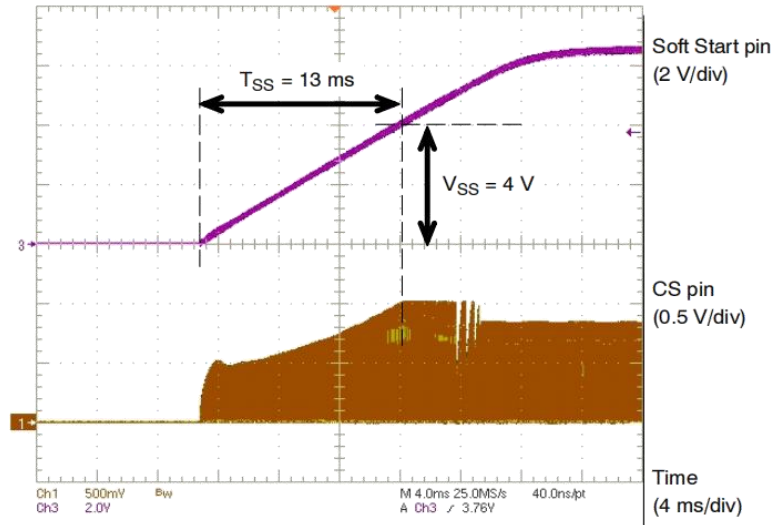


Figure 33. Soft Start Example

### Brown-Out Protection

By monitoring the level on BO pin, the controller protects the forward converter against low input voltage conditions.

When the BO pin level falls below the VBO level, the controller stops pulsing until the input level goes back to normal and resumes the operation via a new soft start sequence.

The brown-out comparator features a fixed voltage reference level (VBO). The hysteresis is implemented by using the internal current connected between the BO pin and the ground when the BO pin is below the internal voltage reference (VBO).

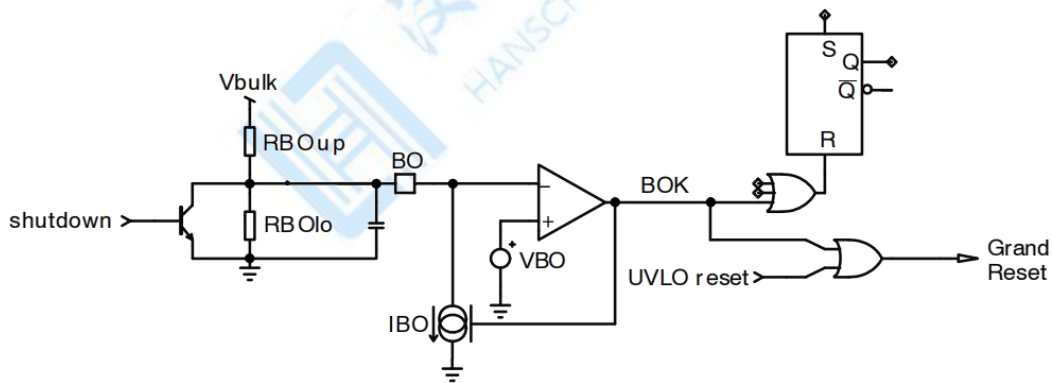


Figure 34. BO Pin Setup

The following equations show how to calculate the resistors for BO pin.

First of all, select the bulk voltage value at which the controller must start switching ( $V_{bulkon}$ ) and the bulk voltage for shutdown ( $V_{bulkoff}$ ) the controller.

Where:

- $V_{bulkon} = 370\text{ V}$
- $V_{bulkoff} = 350\text{ V}$
- $V_{BO} = 1\text{ V}$
- $I_{BO} = 10\mu\text{A}$

When BO pin voltage is below  $V_{BO}$  (internal voltage reference), the internal current source ( $I_{BO}$ ) is activated.

The following equation can be written:

$$R_{BOlo} = \frac{V_{BO}}{I_{BO}} \left( \frac{V_{bulkon} - V_{BO}}{V_{bulkoff} - V_{BO}} - 1 \right) \quad (\text{eq. 4})$$

$R_{BOup}$  can be also written independently of  $R_{BOlo}$  by substituting Equation 4 into Equation 3 as follow:

$$R_{BOup} = \frac{V_{bulkon} - V_{bulkoff}}{I_{BO}} \quad (\text{eq. 5})$$

From Equation 4 and Equation 5, the resistor divider value can be calculated:

$$R_{BOlo} = \frac{1}{10\mu} \left( \frac{370 - 1}{350 - 1} - 1 \right) = 5731\Omega$$

$$R_{BOup} = \frac{370 - 350}{10\mu} = 2.0\text{M}\Omega$$

$$V_{bulkON} = R_{BOup} \left( I_{BO} + \frac{V_{BO}}{R_{BOlo}} \right) + V_{BO} \quad (\text{eq. 1})$$

When BO pin voltage is higher than  $V_{BO}$ , the internal current source is now disabled. The following equation can be written:

$$V_{BO} = \frac{V_{bulkoff} R_{BOlo}}{R_{BOlo} + R_{BOup}} \quad (\text{eq. 2})$$

From Equation 2 it can be extracted the  $R_{BOup}$ :

$$R_{BOup} = \left( \frac{V_{bulkoff} - V_{BO}}{V_{BO}} \right) R_{BOlo} \quad (\text{eq. 3})$$

Equation 3 is substituted in Equation 1 and solved for  $R_{BOlo}$ , yields:

### Short Circuit or Over Load Protection:

A short circuit or an overload situation is detected when the CS pin level reaching its maximum level at 1 V. In that case the fault status is stored in the latch and allows the digital timer count. If the digital timer ends then the fault is latched and the controller permanently stops the pulses on the driver pin.

If the fault is gone before ending the digital timer, the timer is reset only after 3 switching controller periods without fault detection (or when the CS pin < 1 V during at least 3 switching periods).

If the fault is latched the controller can be reset if a BO reset is sensed or if VCC is cycled down to  $V_{CC(off)}$ .

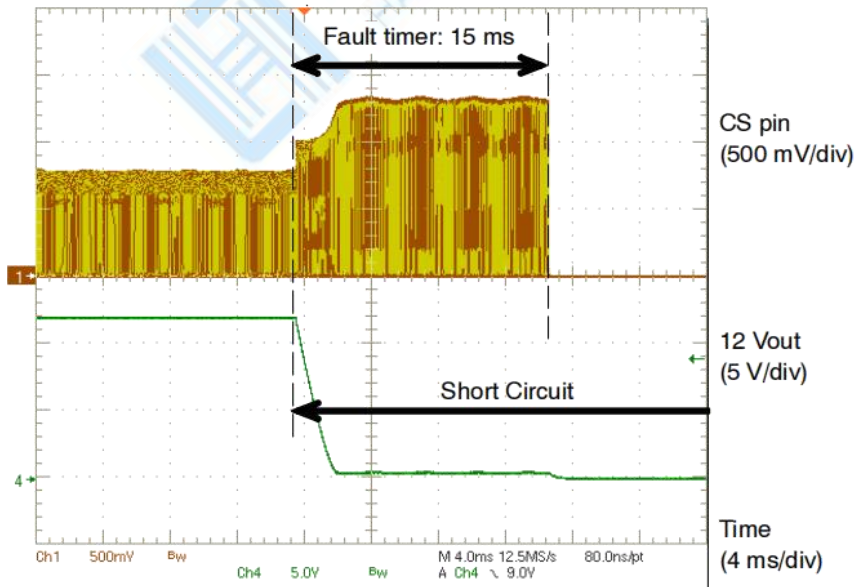


Figure 35. Short Circuit Detection Example

### Shut Down

There is one possibility to shut down the controller; this possibility consists at grounding the BO pin as illustrated in Figure 34.

### Ramp Compensation

Ramp compensation is a known mean to cure subharmonic oscillations. These oscillations take place at half of the switching frequency and occur only during Continuous Conduction Mode (CCM) with a duty-cycle close to and above 50%. To lower the current loop gain, one usually injects between 50 and 100% of the inductor downslope. depicts how internally the ramp is generated:

The ramp compensation applied on CS pin is from the internal oscillator ramp buffered. A switch placed between the buffered internal oscillator ramp and Rramp disconnects the ramp compensation during the OFF time DRV signal.

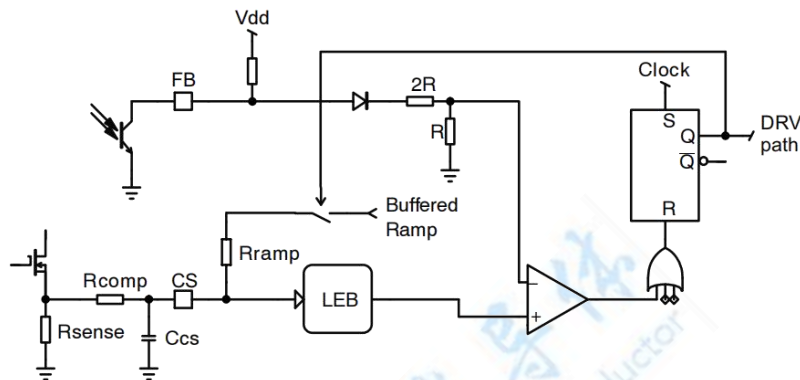


Figure 36. Ramp Compensation Setup

In the NCP1252, the internal ramp swings with a slope of:

$$S_{int} = \frac{V_{int}}{DC_{max}} F_{sw} \quad (\text{eq. 6})$$

In a forward application the secondary-side downslope viewed on a primary side requires a projection over the sense resistor Rsense. Thus:

$$S_{sense} = \frac{(V_{out} + V_f) N_s}{L_{out} N_p} R_{sense} \quad (\text{eq. 7})$$

where:

- Vout is output voltage level
  - Vf the freewheel diode forward drop
  - Lout, the secondary inductor value
  - Ns/Np the transformer turn ratio
  - Rsense: the sense resistor on the primary side
- Assuming the selected amount of ramp compensation to be applied is  $\delta_{comp}$ , then we must calculate the division ratio to scale down Sint accordingly:

$$\text{Ratio} = \frac{R_{sense} \delta_{comp}}{S_{int}} \quad (\text{eq. 8})$$

A few line of algebra determined Rcomp:

$$R_{comp} = R_{ramp} \frac{\text{Ratio}}{1 - \text{Ratio}} \quad (\text{eq. 9})$$

The previous ramp compensation calculation does not take into account the natural primary ramp created by the transformer magnetizing inductance. In some case illustrated here after the power supply does not need additional ramp compensation due to the high level of the natural primary ramp.

The natural primary ramp is extracted from the following formula:

$$S_{natural} = \frac{V_{bulk}}{L_{mag}} R_{sense} \quad (\text{eq. 10})$$

Then the natural ramp compensation will be:

$$\delta_{natural\_comp} = \frac{S_{natural}}{S_{sense}} \quad (\text{eq. 11})$$

If the natural ramp compensation ( $\delta_{natural\_comp}$ ) is higher than the ramp compensation needed ( $\delta_{comp}$ ), the power supply does not need additional ramp compensation. If not, only the difference ( $\delta_{comp} - \delta_{natural\_comp}$ ) should be used to calculate the accurate compensation value.

Thus the new division ratio is:

$$\text{if } \delta_{\text{natural\_comp}} < \delta_{\text{comp}} \rightarrow \text{Ratio} = \frac{S_{\text{sense}}(\delta_{\text{comp}} - \delta_{\text{natural\_comp}})}{S_{\text{int}}} \quad (\text{eq. 12})$$

Then Rcomp can be calculated with the same equation used when the natural ramp is neglected (Equation 9).

### Ramp Compensation Design Example:

2 switch-Forward Power supply specification:

- Regulated output: 12 V
- Lout = 27μh
- Vf = 0.7 V (drop voltage on the regulated output)
- Current sense resistor : 0.75
- Switching frequency : 125 kHz
- Vbulk = 350 V, minimum input voltage at which the power supply works.
- Duty cycle max: DCmax = 84%
- Vramp = 3.5 V, Internal ramp level.
- Rramp = 26.5 k , Internal pull-up resistance
- Targeted ramp compensation level: 100%
- Transformer specification:
  - Lmag = 13m
  - N<sub>s</sub>/N<sub>p</sub> = 0.085

Internal ramp compensation level

$$S_{\text{int}} = \frac{V_{\text{ramp}}}{DC_{\text{max}}} F_{\text{sw}} \rightarrow S_{\text{int}} = \frac{3.5}{0.84} 125 \text{ kHz} = 520 \text{ mV}/\mu\text{s}$$

Secondary-side downslope projected over the sense resistor is:

$$S_{\text{sense}} = \frac{(V_{\text{out}} + V_f) N_s}{L_{\text{out}} N_p} R_{\text{sense}} \rightarrow S_{\text{sense}} = \frac{(12 + 17)}{27 \cdot 10^{-6}} 0.085 \times 0.75 = 29.99 \text{ mV}/\mu\text{s}$$

Natural primary ramp:

$$S_{\text{natural}} = \frac{V_{\text{bulk}}}{L_{\text{mag}}} R_{\text{sense}} \rightarrow S_{\text{natural}} = \frac{350}{13 \cdot 10^{-3}} 0.75 = 20.19 \text{ mV}/\mu\text{s}$$

Thus the natural ramp compensation is:

$$\delta_{\text{natural\_comp}} = \frac{S_{\text{natural}}}{S_{\text{sense}}} \rightarrow \delta_{\text{natural\_comp}} = \frac{20.19}{29.99} = 67.3\%$$

Here the natural ramp compensation is lower than the desired ramp compensation, so an external compensation should be added to prevent sub-harmonics oscillation.

$$\text{Ratio} = \frac{S_{\text{sense}}(\delta_{\text{natural\_comp}})}{S_{\text{int}}} \rightarrow \text{Ratio} = \frac{29.99 \cdot (1.00 - 0.67)}{520} = 0.019$$

We can now calculate external resistor (Rcomp) to reach the correct compensation level.

$$R_{\text{comp}} = R_{\text{ramp}} \frac{\text{Ratio}}{1 - \text{Ratio}} \rightarrow R_{\text{comp}} = 26.5 \cdot 10^3 \frac{0.019}{1 - 0.019} = 509 \Omega$$



Thus with  $R_{comp} = 510$  , 100% compensation ramp is applied on the CS pin.

The following example illustrates a power supply where the natural ramp offers enough ramp compensation to avoid external ramp compensation.

2 switch-Forward Power supply specification:

- Regulated output: 12 V
- $L_{out} = 27\mu H$
- $V_f = 0.7$  V (drop voltage on the regulated output)
- Current sense resistor:  $0.75\Omega$
- Switching frequency: 125 kHz
- $V_{bulk} = 350$  V, minimum input voltage at which the power supply works.
- Duty cycle max:  $DC_{max} = 84\%$
- $V_{ramp} = 3.5$  V, Internal ramp level.
- $R_{ramp} = 26.5$  k , Internal pull-up resistance
- Targeted ramp compensation level: 100%
- Transformer specification:
  - $L_{mag} = 13m$
  - $N_s/N_p = 0.085$

Secondary-side downslope projected over the sense resistor is:

$$S_{sense} = \frac{(V_{out} + V_f) N_s}{L_{put} N_p} R_{sense} \rightarrow S_{sense} = \frac{(12 + 0.7)}{27 \cdot 10^{-6}} 0.085 \times 0.75 = 29.99 mV/\mu s$$

The natural primary ramp is:

$$S_{natural} = \frac{(V_{bulk})}{L_{mag}} R_{sense} \rightarrow S_{natural} = \frac{350}{7 \cdot 10^{-3}} 0.75 = 37.5 mV/\mu s$$

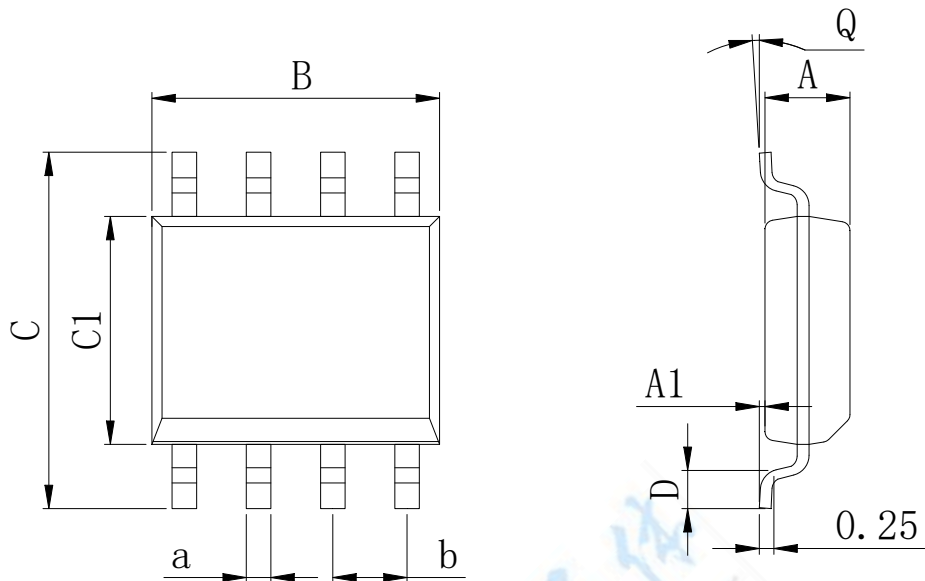
And the natural ramp compensation will be:

$$\delta_{natural\_comp} = \frac{S_{natural}}{S_{sense}} \rightarrow \delta_{natural\_comp} = \frac{37.5}{29.99} = 125\%$$

So in that case the natural ramp compensation due to the magnetizing inductance of the transformer will be enough to prevent any sub-harmonics oscillation in case of duty cycle above 50%.

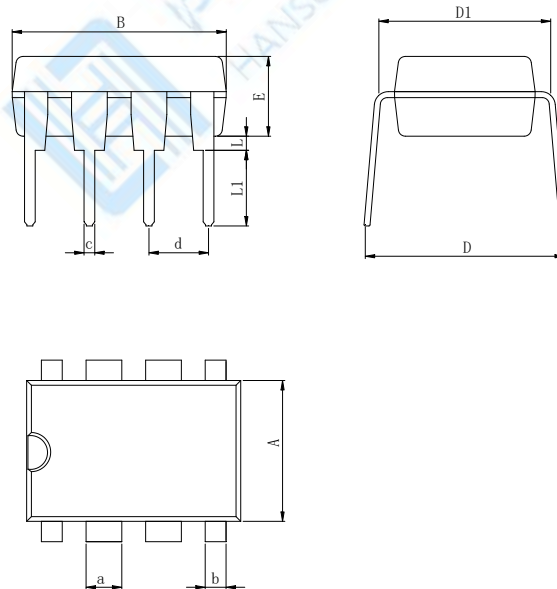
**Physical Dimensions**

SOP-8L 150mil


**Dimensions In Millimeters(SOP8L)**

Symbol:	A	A1	B	C	C1	D	Q	a	b
Min:	1.35	0.05	4.90	5.80	3.80	0.40	0°	0.35	1.27 BSC
Max:	1.55	0.20	5.10	6.20	4.00	0.80	8°	0.45	

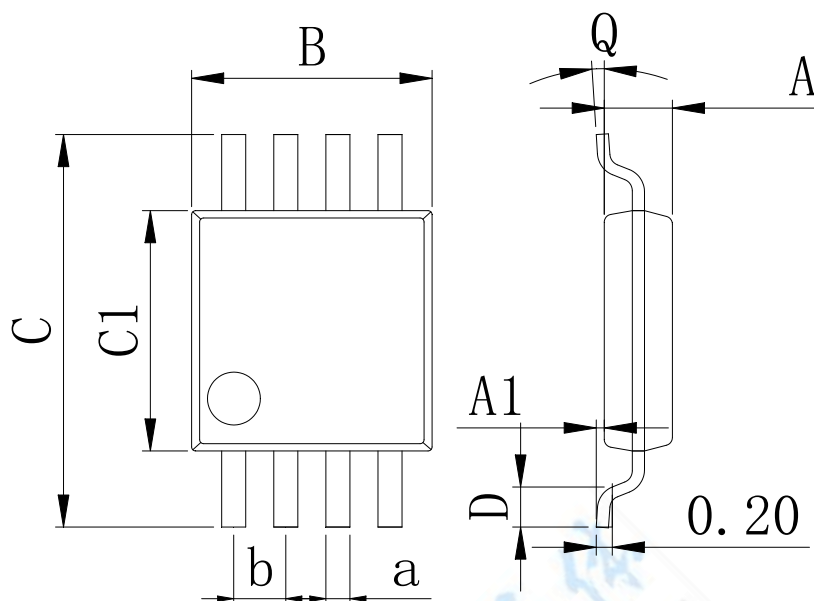
DIP-8L


**Dimensions In Millimeters(DIP8L)**

Symbol:	A	B	D	D1	E	L	L1	a	b	c	d
Min:	6.10	9.00	8.40	7.42	3.10	0.50	3.00	1.50	0.85	0.40	2.54 BSC
Max:	6.68	9.50	9.00	7.82	3.55	0.70	3.60	1.55	0.90	0.50	

**Physical Dimensions**

MSOP8



Dimensions In Millimeters(MSOP8L)									
Symbol:	A	A1	B	C	C1	D	Q	a	b
Min:	0.80	0.05	2.90	4.75	2.90	0.35	0°	0.25	0.65 BSC
Max:	0.90	0.20	3.10	5.05	3.10	0.75	8°	0.35	

**IMPORTANT STATEMENT:**

**Shenzhen Hanschip semiconductor co.,ltd. reserves the right to change the products and services provided without notice. Customers should obtain the latest relevant information before ordering, and verify the timeliness and accuracy of this information.**

**Customers are responsible for complying with safety standards and taking safety measures when using our products for system design and machine manufacturing to avoid potential risks that may result in personal injury or property damage.**

**Our products are not licensed for applications in life support, military, aerospace, etc., so we do not bear the consequences of the application of these products in these fields.**

**Our documentation is only permitted to be copied without any tampering with the content, so we do not accept any responsibility or liability for the altered documents.**

