

3-phase Sensor-less Fan Motor Driver

AM2355N

The AM2355N is a 3-phase sensor-less DC fan motor driver IC. It senses the BEMF (Back Electro-Motive Force) of the motor in rotation and provides corresponding commutation current to the motor. Rotation speed can be controlled by PWM input signal. The drivers include Lock Detection, Thermal Shutdown, and Over-current Protection. Forward and Reverse control.

● Applications

3-phase sensor-less DC Fan Motor

● Features

- | | |
|--|--|
| 1) Operation voltage 1.8 to 6.0V | 6) PWM speed control |
| 2) Lock detection/Automatic restart function | 7) Soft switching technique to reduce acoustic noise |
| 3) Built-in FG (frequency generation) | 8) Forward and Reverse control |
| 4) Thermal shutdown protection | |
| 5) Over current protection | |

● Absolute Maximum Ratings (Ta = 25°C)

Parameter	Symbol	Limits	Unit
Supply voltage	V_{CC}	6.5	V
Output Peak current	I_{omax}	1000	mA
Output Continuous current	I_o	450	mA
FG signal output voltage	V_{FG}	6.5	V
FG signal output current	I_{FG}	10	mA
PWM input voltage	$VPWM_{max}$	V_{cc}	V
Power dissipation (JEDEC 2S2P PCB)	P_d	3270*	mW
Operate temperature range	T_{opr}	-40 ~ +125	°C
Storage temperature range	T_{stg}	-55 ~ +150	°C
Junction temperature	T_{jmax}	150	°C

* Pd de-rated by 26.2mW/°C over 25°C (based on JEDEC 2S2P board)

Those are stress rating only and functional operating at those conditions for extended periods may damage to the device.

● Recommended operating conditions

(Set the power supply voltage taking allowable dissipation into considering)

Parameter	Symbol	Min	Typ	Max	Unit
Operating supply voltage range	V_{cc}		1.8 ~ 6.0		V

● **Storage Condition**

Parameter	Value	Unit
Temperature condition Before Opening	5~40	°C
Humidity condition Before Opening	30~80%	RH
Temperature condition after Opening	<30	°C
Humidity condition after Opening	<60%	RH

● **Electrical Characteristics**

(Unless otherwise specified, Ta = 25°C, VCC = 5.0V)

Parameter	Symbol	Limit			Unit	Conditions
		Min	Typ	Max		
Supply current	I _{CC}	—	1.8	3	mA	PWM pin= VCC
Stand-by current	I _{SC}	—	25	50	μA	PWM pin= 0V
Oscillator						
OSC pin charge current	I _{OSC1}	-10.4	-12.5	-14.6	μA	OSC pin= 0.5V
OSC pin discharge current	I _{OSC2}	10.4	12.5	14.6	μA	OSC pin= 1.5V
FR/PWM input						
Input H level	V _{PWMH}	2.5	—	V _{CC}	V	
Input L level	V _{PWML}	0	—	V _{CC} *0.2	V	
PWM input frequency	F _{PWM}	20	—	50	kHz	
Output						
Output voltage	V _O	—	0.3	0.4	V	I _O =250mA (Upper + Lower)
FG low voltage	V _{FGL}	—	—	0.4	V	I _{FG} = 5mA
FG leakage current	I _{FGL}	—	—	10	μA	V _{FG} = 5V
Lock protection						
Lock detection ON time	T _{ON}	1.4	2	2.6	sec	T _{ON} =start time + lock detect
Lock detection OFF time	T _{OFF}	3.5	5	6.5	sec	
Thermal						
Thermal shutdown	ThSD	150	170	—	°C	
Thermal shutdown hysteresis	ΔThSD		25		°C	

● Block Diagram

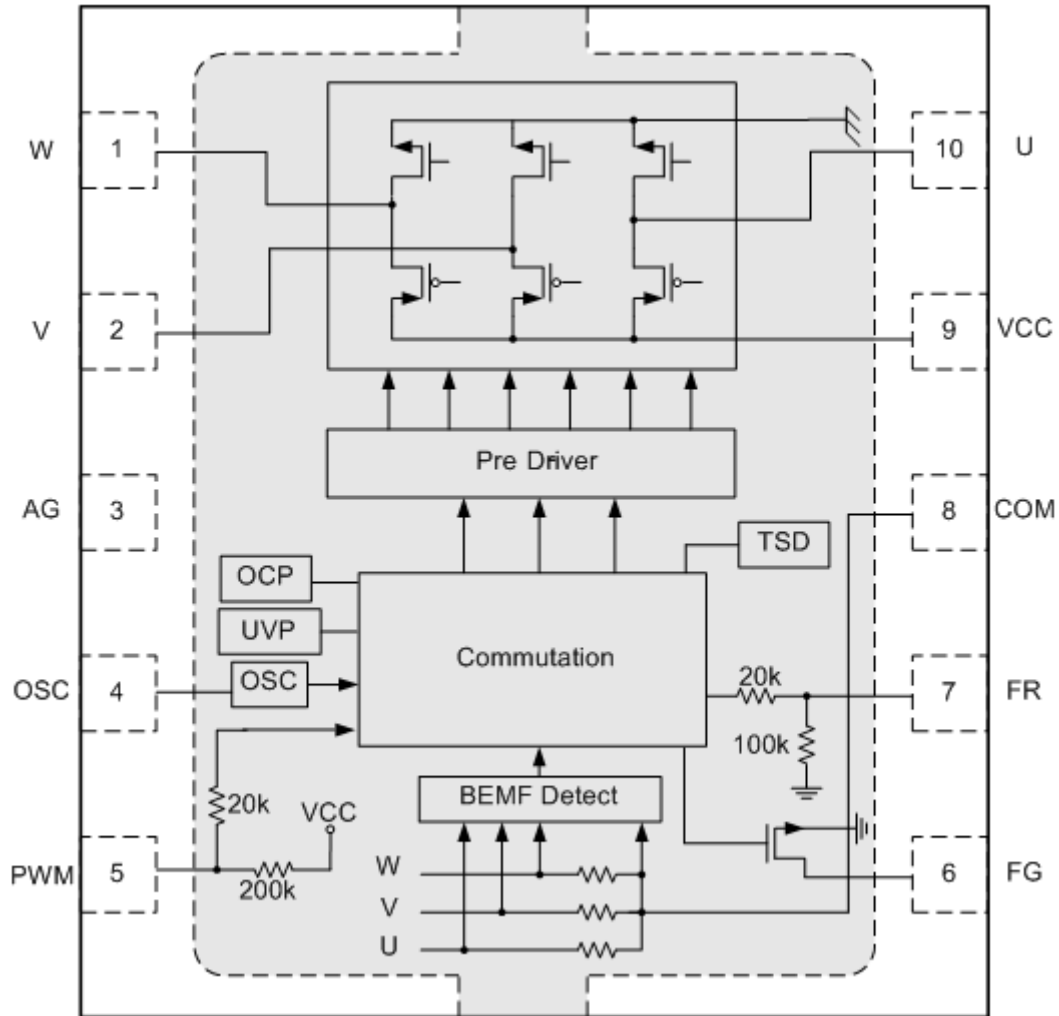

Fig.1 Block diagram

● Pin Description

PIN No	Pin Name	Function
1	W	W phase output terminal
2	V	V phase output terminal
3	AG	Analog ground terminal
4	OSC	Start-up frequency output terminal
5	PWM	PWM signal input terminal
6	FG	FG signal output terminal
7	FR	Forward and Reverse control terminal
8	COM	Motor center tap voltage input terminal
9	VCC	Power supply terminal
10	U	U phase output terminal
E-pad	PG	Power ground terminal

● **Thermal Information**

Θ_{ja}	junction-to-ambient thermal resistance	38.23°C/W
Ψ_{jt}	junction-to-top characterization parameter	0.11°C/W

- **Θ_{ja}** is obtained in a simulation on a JEDEC-standard 2s2p board as specified in JESD-51.
- The **Θ_{ja}** number listed above gives an estimate of how much temperature rise is expected if the device was mounted on a standard JEDEC board.
- When mounted on the actual PCB, the **Θ_{ja}** value of JEDEC board is totally different than the **Θ_{ja}** value of actual PCB.
- **Ψ_{jt}** is extracted from the simulation data to obtain **Θ_{ja}** using a procedure described in JESD-51, which estimates the junction temperature of a device in an actual PCB.
- The thermal characterization parameter, **Ψ_{jt}**, is proportional to the temperature difference between the top of the package and the junction temperature. Hence, it is useful value for an engineer verifying device temperature in an actual PCB environment as described in JEDEC JESD-51-12.
- When Greek letters are not available, **Ψ_{jt}** is written Psi-jt.
- Definition:

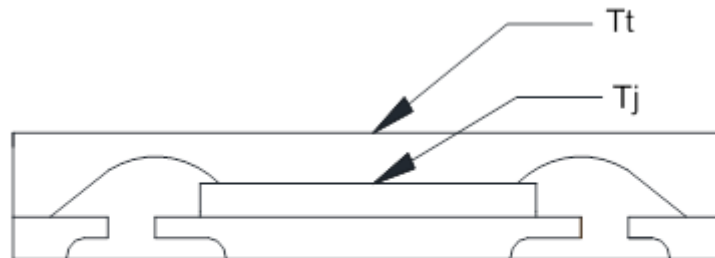

DEFINITION
$$\psi_{jt} = (T_j - T_t) / P_d$$

Where :

- Ψ_{jt}** (Psi-jt) = Junction-to-Top(of the package) °C/W
- T_j**= Die Junction Temp. °C
- T_t**= Top of package Temp at center. °C
- P_d**= Power dissipation. Watts

- Practically, most of the device heat goes into the PCB, there is a very low heat flow through top of the package, So the temperature difference between **T_j** and **T_t** shall be small, that is any error caused by PCB variation is small.
- This constant represents that **Ψ_{jt}** is completely PCB independent and could be used to predict the **T_j** in the environment of the actual PCB if **T_t** is measured properly.

- **How to predict Tj in the environment of the actual PCB**

Step 1 : Used the simulated Ψ_{jt} value listed above.

Step 2 : Measure **Tt** value by using

- **Thermocouple Method**

We recommend use of a small ~40 gauge(3.15mil diameter) thermocouple. The bead and thermocouples wires should touch the top of the package and be covered with a minimal amount of thermally conductive epoxy. The wires should be heat-insulated to prevent cooling of the bead due to heat loss into wires. This is important towards preventing “too cool” **Tt** measurements, which would lead to the calculated **Tj** also being too cool.

- **IR Spot Method**

An IR Spot method should be utilized only when using a tool with a small enough spot area to acquire the true top center “hot spot”.

Many so-called “small spot size” tools still have a measurement area of 0~100+mils at “zero” distance of the tool from the surface. This spot area is too big for many smaller packages and likely would result in cooler readings than the small thermocouple method. Consequently, to match between spot area and package surface size is important while measuring **Tt** with IR sport method.

Step 3 : calculating power dissipation by

$$P \cong (VCC - |V_{o_Hi} - V_{o_Lo}|) \times I_{out} + VCC \times I_{cc}$$

Step 4 : Estimate **Tj** value by

$$T_j = \Psi_{jt} \times P + T_t$$

Step 5: Calculated Θ_{ja} value of actual PCB by the known **Tj**

$$\Theta_{ja}(\text{actual}) = (T_j - T_a) / P$$

Maximum Power Dissipation (de-rating curve) under JEDEC PCB & actual PCB

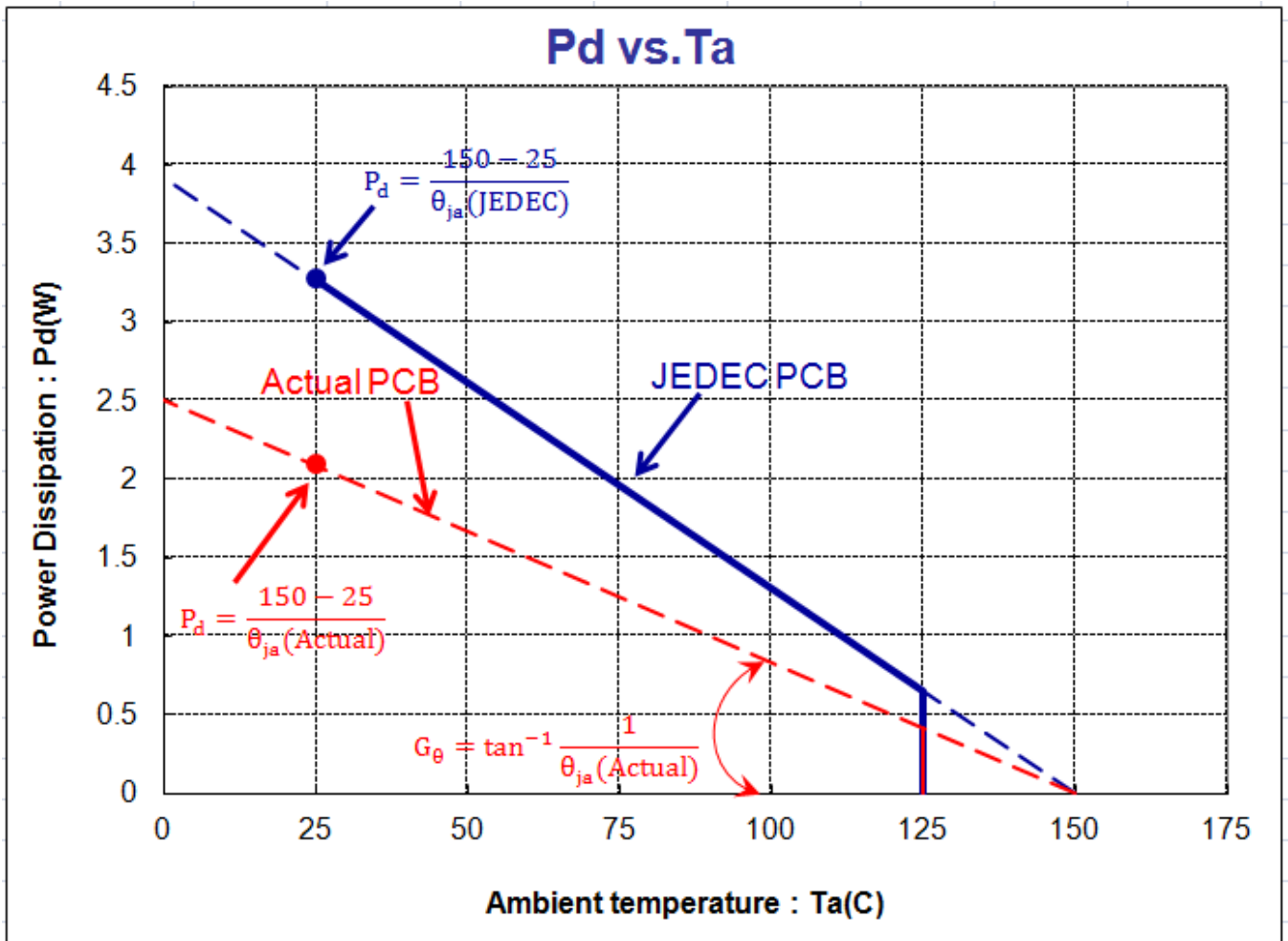

● Application circuit

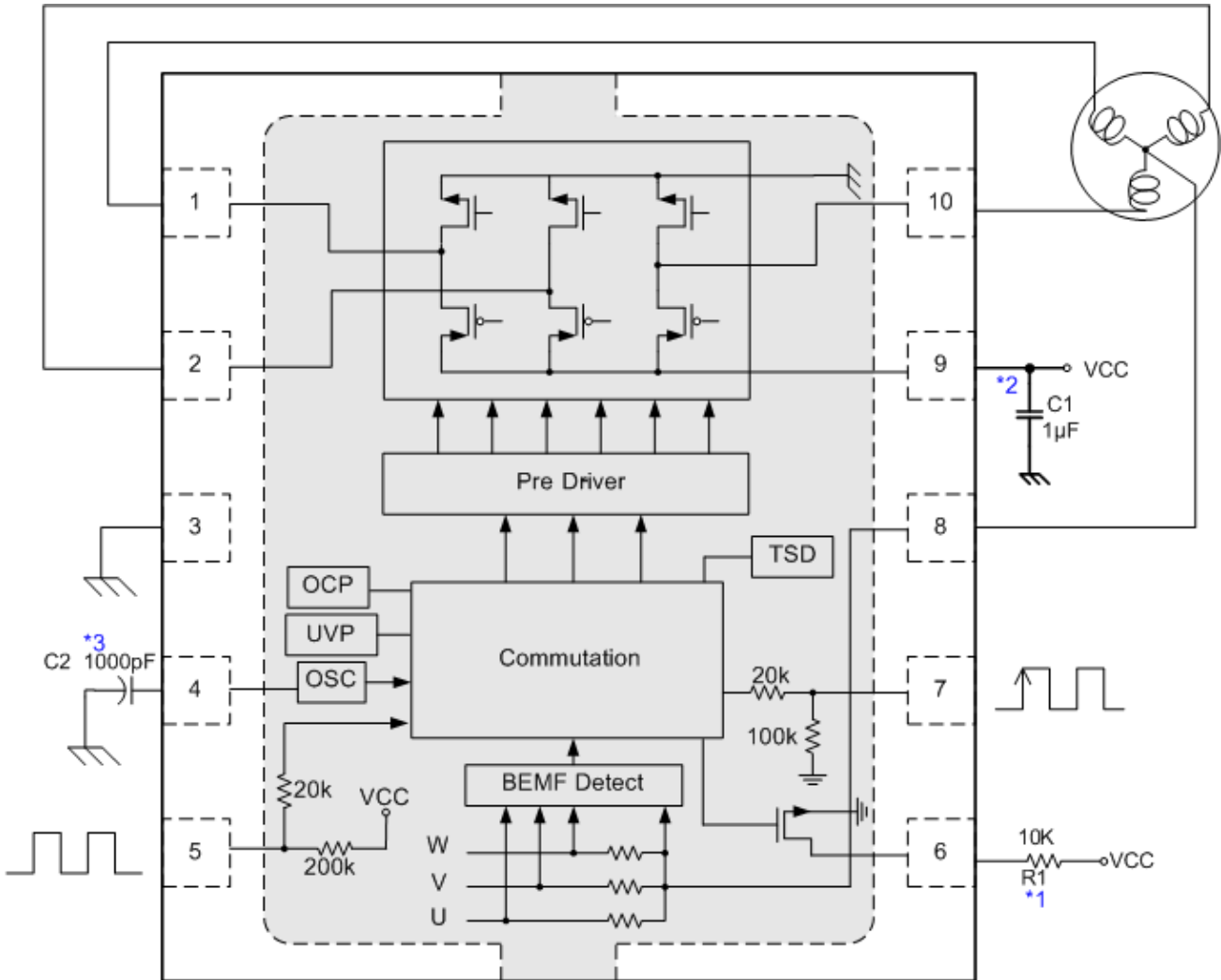

Fig. 2 Application circuit

- *1 Open drain output. A pull-up resistances of 10kΩ should be inserted.
- *2 The wiring patterns from the VCC terminal and GND terminal to the bypass capacitor must be routed as short as possible. With respect to the wiring pattern
- *3 This Capacitor 1000pF is only for reference. Variable Motors should select suitable capacitor for optimum start-up characteristics.

● Operation notes

1) Power supply line

The BEMF causes re-circulate current to power supply, please connect a capacitor between power supply and ground as a route of re-circulate current. And please determine the capacitance after confirmation that the capacitance does not causes any problems.

2) Ground potential

Ground potential AG and PG pin connect the lowest voltage on the chip and short the path as possible.

3) PWM speed control

This IC offer PWM pin direct control output transistors for motor speed control. Higher frequency will reduce output current noise. The control input frequency recommended operation between 20 KHz to 50 KHz. If PWM Low is slower than 150us (typ.), it will go into stand-by mode.

This pin connect internal pull-high resistor 200K ohm. When connect to VCC or floating. The motor will rotate in the full speed.

4) Soft Switching Circuit

This IC use duty-variable switching for low acoustic noise and vibration.

5) Start-up Circuits

The OSC pin is defined a sensor-less start-up commutation frequency. The connecting capacitor is between the OSC pin and ground. Variable Motors start-up characteristic are variable with different capacitors. Variable Motors should select suitable capacitor for optimum start-up characteristics. If the capacitance value is larger, the variation start-up time is longer. Also, if the capacitance value is smaller, the motor start-up time is shorter and might cause start-up failed by fan friction.

6) Start-up Test

In order to make sure start-up normally, after choose OSC capacitor value, it should test every PWM Duty for start-up. Normal start-up test would test PWM Duty 100%~20%, every 5% PWM duty step for each point, make sure start-up status.

Even the Fan Coil (U, V, W) BEMF are meet the condition as Fan BEMF Requirement, it still need to do the start-up test to verify the start-up status.

7) FG (Function Generator) function

This FG pin is made up with an open drain output. Recommend connect a resistance of 10k ohm to VCC.

8) Thermal design and Thermal shutdown

The thermal design should allow enough margins for actual power dissipation. In case the IC is left running over the allowable loss, the junction temperature rises, and the thermal-shutdown circuit works at the junction temperature of 170°C (typ.) (the outputs of all the channels are turned off). When the junction temperature drops to 145°C (typ.), the IC start operating again.

9) FR (Forward and Reverse) function

FR high: U -> V-> W ; FR low: U->W->V ◦ There is a internal pull low 100kΩ resistor which means the default setting is low if this pin is floating. Motor direction can be forward or reverse by switching FR Voltage level. When motor direction is going to be changed, larger pick current level will be happened. Please consider the current and power dissipation.

● **Fan BEMF Requirement**

1. Fan Coil (U, V, W) BEMF amplitude minimum need to over 40mV at 1000rpm.
2. Fan Coil (U, V, W) BEMF Zero Cross Slope need equal or greater than SINE wave within $\pm 15\text{mV}$.

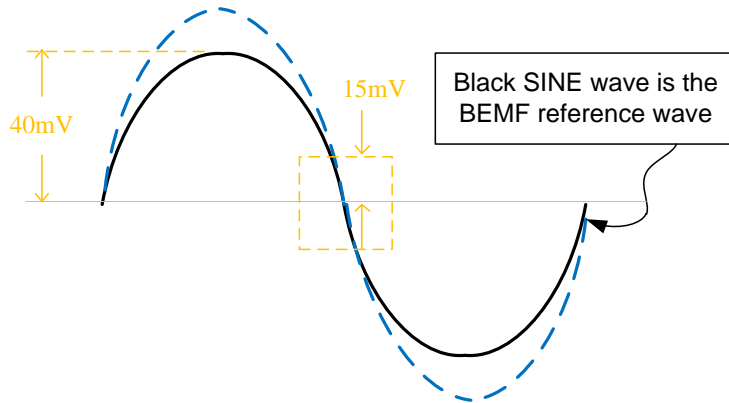

3. Acceptable.

- A. BEMF wave greater than 40mV
- B. BEMF wave greater than 40mV. The wave middle side need to greater than $\pm 20\text{mV}$.

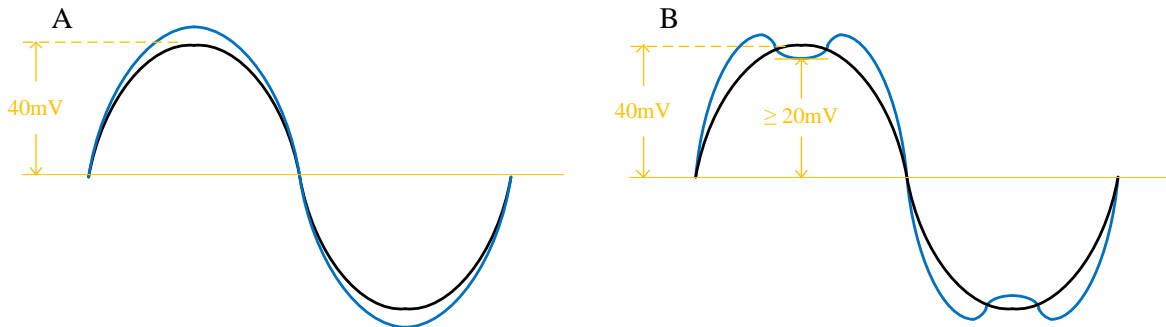

4. Unacceptable

- C. BEMF wave smaller than 40mV.
- D. BEMF Zero Cross Slope less than SINE wave within $\pm 15\text{mV}$.

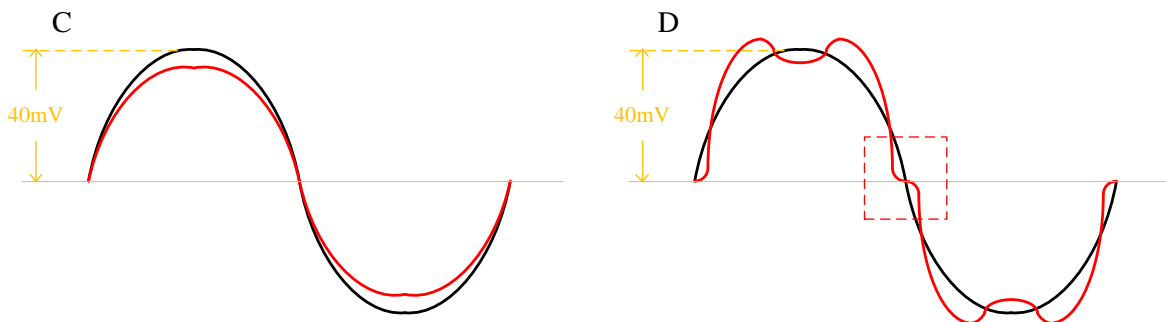

● Package Outline --- DFN 3X3 10L

Unit : mm

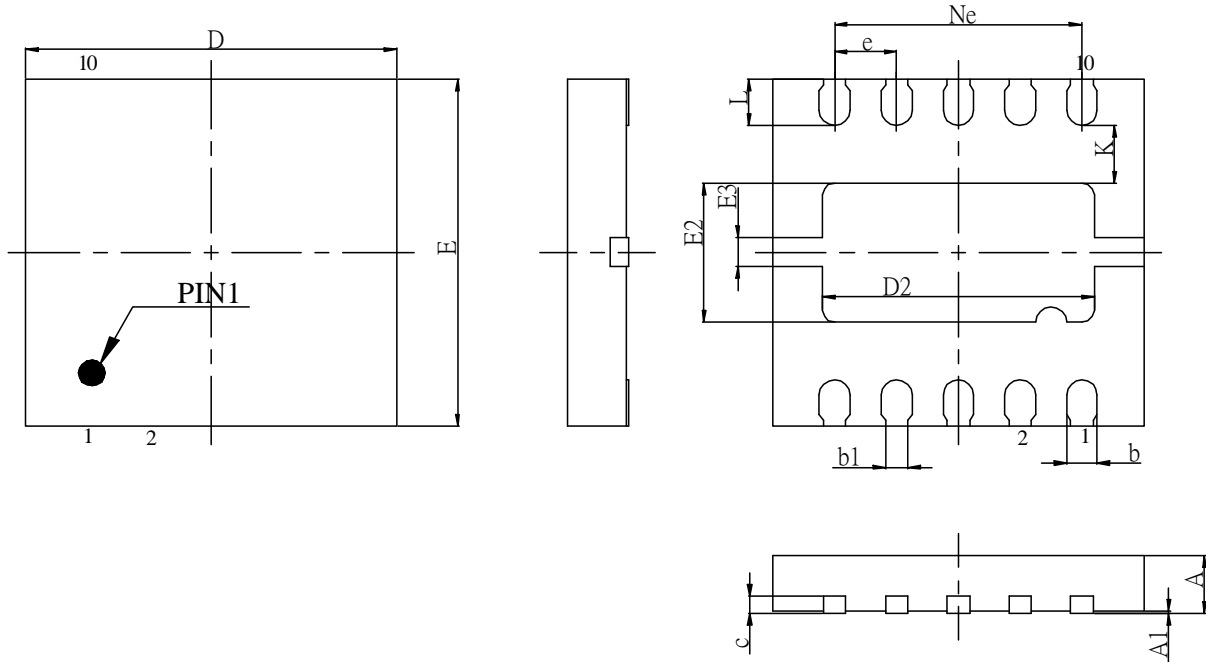

SYMBOL	MILLIMETERS		INCHES	
	Min.	Max.	Min.	Max.
A	-	0.60	-	0.024
A1	-	0.05	-	0.002
c	0.15 REF		0.006 REF	
b	0.20	0.30	0.008	0.012
b1	0.18 REF		0.007 REF	
D/E	2.95	3.05	0.116	0.120
D2	2.10	2.30	0.083	0.091
E2	1.10	1.30	0.043	0.051
E3	0.20	0.30	0.008	0.012
L	0.30	0.50	0.012	0.020
e	0.5 BSC		0.020 BSC	

● **Reflow profile**

(A) Manual Soldering

Time / Temperature $\leq 3 \text{ sec} / 390 \pm 10^\circ\text{C}$ (2 Times)

Test Results : 0 fail/ 22 tested

Manual Soldering count : 2 Times

(B). Re-flow Soldering (follow IPC/JEDEC J-STD-020D)

Classification Reflow Profile

Profile Feature	Pb-Free Assembly
Average ramp-up rate (T_L to T_p)	3°C/second max.
Preheat <ul style="list-style-type: none"> - Temperature Min ($T_{s \text{ min}}$) - Temperature Max ($T_{s \text{ max}}$) - Time (t_s) from ($T_{s \text{ min}}$ to $T_{s \text{ max}}$) 	150°C 200°C 60-120 seconds
$T_{s \text{ max}}$ to T_L <ul style="list-style-type: none"> - Temperature Min ($T_{s \text{ min}}$) 	3°C/second max.
Time maintained above: <ul style="list-style-type: none"> - Liquid us temperature (T_L) - Time (t_l) maintained above T_L 	217°C 60-150 seconds
Peak package body temperature (T_p)	260 +0/-5°C
Time with 5°C of actual Peak <ul style="list-style-type: none"> - Temperature (t_p) 	30 seconds
Ramp-down Rate	6°C/second max.
Time 25°C to Peak Temperature	8 minutes max.

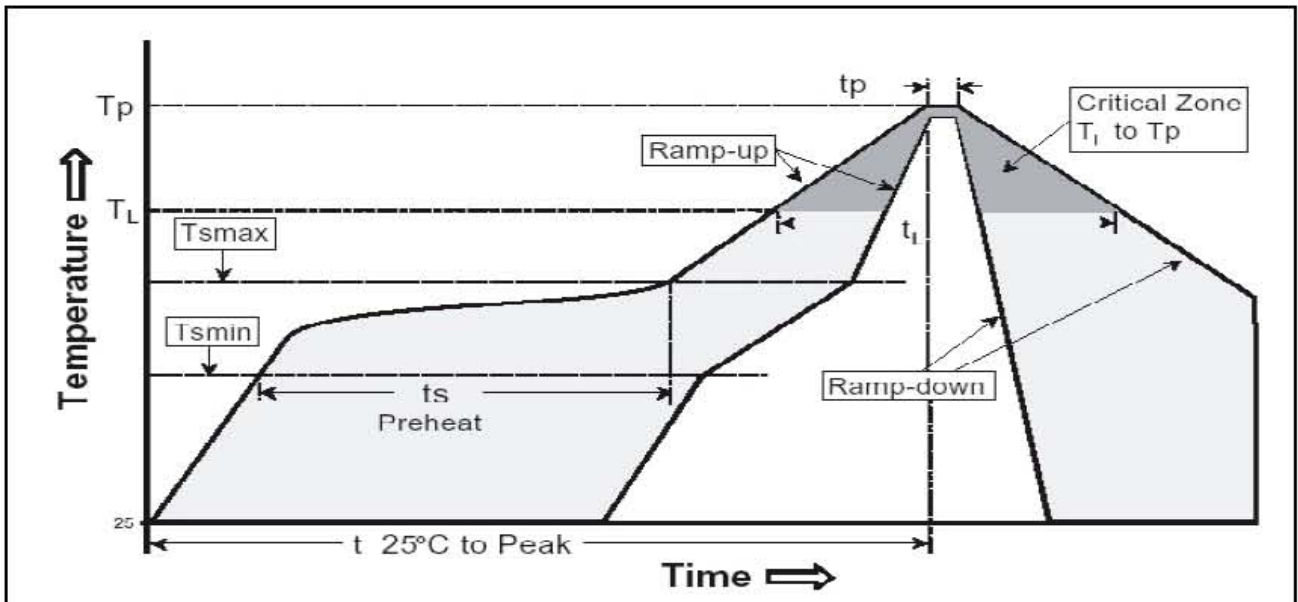

Test Results : 0 fail/ 32 tested Reflow count : 3 cycles

● **Marking Identification**

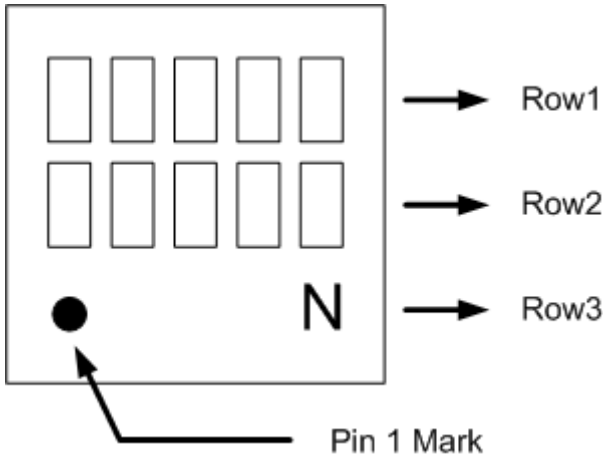

Row 1
A2355

Row 2
Date & Lot number

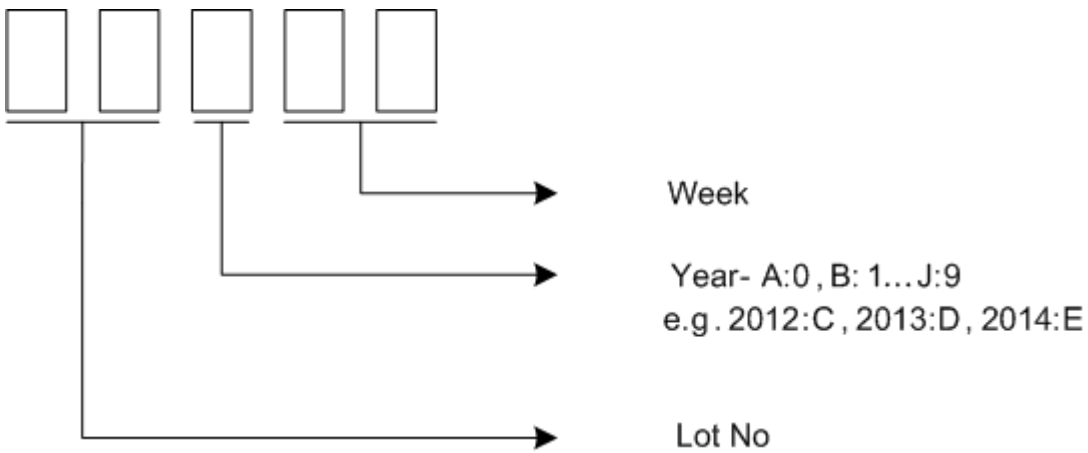

Row 3
N: New