



THINKING ELECTRONIC INDUSTRIAL CO., LTD.

HEAD OFFICE: 12F, No.93, Dashun 1st Rd., Zuoying Dist., Kaohsiung, Taiwan
TEL: 886-7-5577660 FAX: 886-7-5570560

MANUFACTURING SITE

- KAOHSIUNG FACTORY 1: No. 51, Kaifa Rd., N.E.P.Z, Kaohsiung City 81170, Taiwan
TEL: 886-7-9616668 FAX: 886-7-9616698
- KAOHSIUNG FACTORY 2: No. 2-2, Xinjian S. Rd., N.E.P.Z., Kaohsiung City 81170, Taiwan
TEL: 886-7-9630001 FAX: 886-7-3635113
- CHANGZHOU FACTORY: No.6 Longmen Rd., Wujin High & New-Tech Industrial
Development Zone, Changzhou, Jiangsu, China 213161
TEL:86-519-86578999 FAX:86-519-86558643
- DONG GUAN FACTORY: No.45, East Rd., Sha-Tao Dist., Chang-An Town,
Dongguan City, Guangdong, China 523863
TEL:86-769-85542016 FAX:86-769-85546890
- YICHANG FACTORY: No. 283 Xiaoting Avenue, Xiaoting Dist., Yichang
City 443007, Hubei, China
TEL:86-717-6510010 FAX:86-717-6511430



SPECIFICATION FOR APPROVAL

CUSTOMER _____
 CERTIFIED _____
 MODEL/TYPE _____
 PART NO. PLA03151NP8D2XFA(RoHS) _____
 APPLICATION _____
 CUSTOMER P/N _____
 ISSUE DATE Dec.12.2018 _____
 REV. NO. _____
 REV. DATE _____

FOR CUSTOMER APPROVAL	CHECKED BY
	<i>Haili Gong</i>
	APPROVED BY
	<i>Huaifang Zhang</i>





REVISED RECORD SHEET

REV. NO	REV. DATE	REVISED CONTENT



INDEX	Page
■ Part Number Code	1
■ Structure and Dimensions	2
■ Electrical Characteristics	2
■ Reliability	3
■ Soldering Recommendation	4
■ RoHS Compliant Declaration	5
■ Warehouse Storage Conditions of Products	5
■ Taping and Dimensions	6
■ Standard Packing	7
■ Certificates	8

Part Number Code

Example :

PL **A** **03** **151** **N** **P8** **D2** **X** **FA**
 (1) (2) (3) (4) (5) (6) (7) (8) (9)

No.	Item	Digit	Specification
(1)	Product Type	PL	Thinking PTC thermistor for switching type
(2)	Type Series	A	Lead type
(3)	Body Size	03	φ3mm
(4)	Resistance (R ₂₅)	151	15*10 ¹ Ω=150Ω
(5)	Tolerance of R ₂₅	N	±30%
(6)	Curie Temperature	P8	80°C
(7)	Withstanding Voltage	D2	420V
(8)	Packaging	X	RoHS compliance &Taping & Ammo Box
(9)	Optional Suffix	FA	Silicon coating

Structure and Dimensions

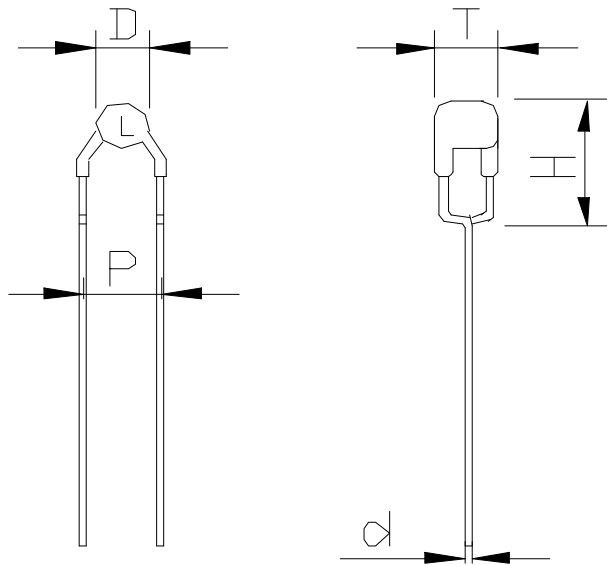

(unit : mm)

Item	D	T	P	d	H
Max.	4.5	4.5	6.0	0.52	8.5
Min.	2.0	3.0	4.0	0.48	---

Electrical Characteristics

Part No.	Curie Temperature	Zero-power Resistance at 25±1/2°C	Withstanding Voltage	Max. Current	Rated Voltage	Max. Voltage	Operating Temperature Range (V=Vmax)	Operating Temperature Range (V=0)
	T _c (°C)	R ₂₅ (Ω)	V _w (V)	I _{max} (mA)	V _R (V)	V _{max} (V)	(°C)	(°C)
PLA03151NP8D2XFA	80±10	150±30%	420	200	220	270	0~+60	-25~+125

Reliability

Item	Standard	Test conditions / Methods	Specifications															
Robustness of Terminations	IEC 60738-1	Gradually apply the specified force and keep the unit fixed for 10±1 sec. <table style="margin-left: auto; margin-right: auto;"> <tr> <td style="text-align: center;">Terminal diameter (mm)</td> <td style="text-align: center;">Force T±10% (N)</td> </tr> <tr> <td style="text-align: center;">0.35<d≤0.5</td> <td style="text-align: center;">5.0</td> </tr> <tr> <td style="text-align: center;">0.5<d≤0.8</td> <td style="text-align: center;">10.0</td> </tr> <tr> <td style="text-align: center;">0.8<d≤1.25</td> <td style="text-align: center;">20.0</td> </tr> </table>	Terminal diameter (mm)	Force T±10% (N)	0.35<d≤0.5	5.0	0.5<d≤0.8	10.0	0.8<d≤1.25	20.0	$ \Delta R_{25}/R_{25} \leq 20\%$ No visible damage							
Terminal diameter (mm)	Force T±10% (N)																	
0.35<d≤0.5	5.0																	
0.5<d≤0.8	10.0																	
0.8<d≤1.25	20.0																	
Solderability	IEC 60738-1	245 ± 3 °C , 2± 0.5sec	At least 95% of terminal electrode is covered by new solder															
Resistance to Soldering Heat	IEC 60738-1	260 ± 3 °C , 10 ± 1 sec	$ \Delta R_{25}/R_{25} \leq 20\%$ No visible damage															
Vibration	IEC 60738-1	Frequency range:10~55Hz Amplitude:0.75mm or 98m/S ² Direction:3 mutually perpendicular directions Duration :6HRS(3x2HRS)	$ \Delta R_{25}/R_{25} \leq 20\%$ No visible damage															
Shock	IEC 60738-1	Wave:half-sine ΔV:1.0m/s Acceleration:50m/s ² Plus time : 30ms	$ \Delta R_{25}/R_{25} \leq 20\%$ No visible damage															
Rapid Change of Temperature	IEC 60738-1	The thermal shock conditions shown below shall be repeated 5 cycles <table border="1" style="margin-left: auto; margin-right: auto;"> <thead> <tr> <th>Step</th> <th>Temperature(°C)</th> <th>Period(minutes)</th> </tr> </thead> <tbody> <tr> <td style="text-align: center;">1</td> <td style="text-align: center;">-40 ± 5</td> <td style="text-align: center;">30 ± 3</td> </tr> <tr> <td style="text-align: center;">2</td> <td style="text-align: center;">Room temperature</td> <td style="text-align: center;">5 ± 3</td> </tr> <tr> <td style="text-align: center;">3</td> <td style="text-align: center;">85 ± 5</td> <td style="text-align: center;">30 ± 3</td> </tr> <tr> <td style="text-align: center;">4</td> <td style="text-align: center;">Room temperature</td> <td style="text-align: center;">5 ± 3</td> </tr> </tbody> </table>	Step	Temperature(°C)	Period(minutes)	1	-40 ± 5	30 ± 3	2	Room temperature	5 ± 3	3	85 ± 5	30 ± 3	4	Room temperature	5 ± 3	$ \Delta R_{25}/R_{25} \leq 20\%$ No visible damage
Step	Temperature(°C)	Period(minutes)																
1	-40 ± 5	30 ± 3																
2	Room temperature	5 ± 3																
3	85 ± 5	30 ± 3																
4	Room temperature	5 ± 3																
Climatic Sequence	IEC 60738-1	Dry heat: 125 °C for 16 hrs Damp heat first cycle: 40°C, 95% R.H, cycle time: 24 hrs Cold: -25°C for 2 hrs Damp heat (cyclic), remaining cycles: 5 cycles Test according to IEC60068-2-30	$ \Delta R_{25}/R_{25} \leq 20\%$ No visible damage															
Damp Heat, Steady State	IEC 60738-1	40±2°C, 90~95% RH, for 1000±2hrs	$ \Delta R_{25}/R_{25} \leq 20\%$ No visible damage															
Endurance at maximum operating temperature and maximum voltage	IEC 60738-1	UCT=60°C, 270Vac, I ≤ I _{max} for 1000±2hrs.	$ \Delta R_{25}/R_{25} \leq 20\%$ No visible damage															
Endurance at maximum voltage	IEC 60738-1	25±5°C, 270Vac, I ≤ I _{max} 1min. on and 5min. Off ×10,000 cycles	$ \Delta R_{25}/R_{25} \leq 20\%$ No visible damage															

Soldering Recommendation

■ Wave Soldering Profile

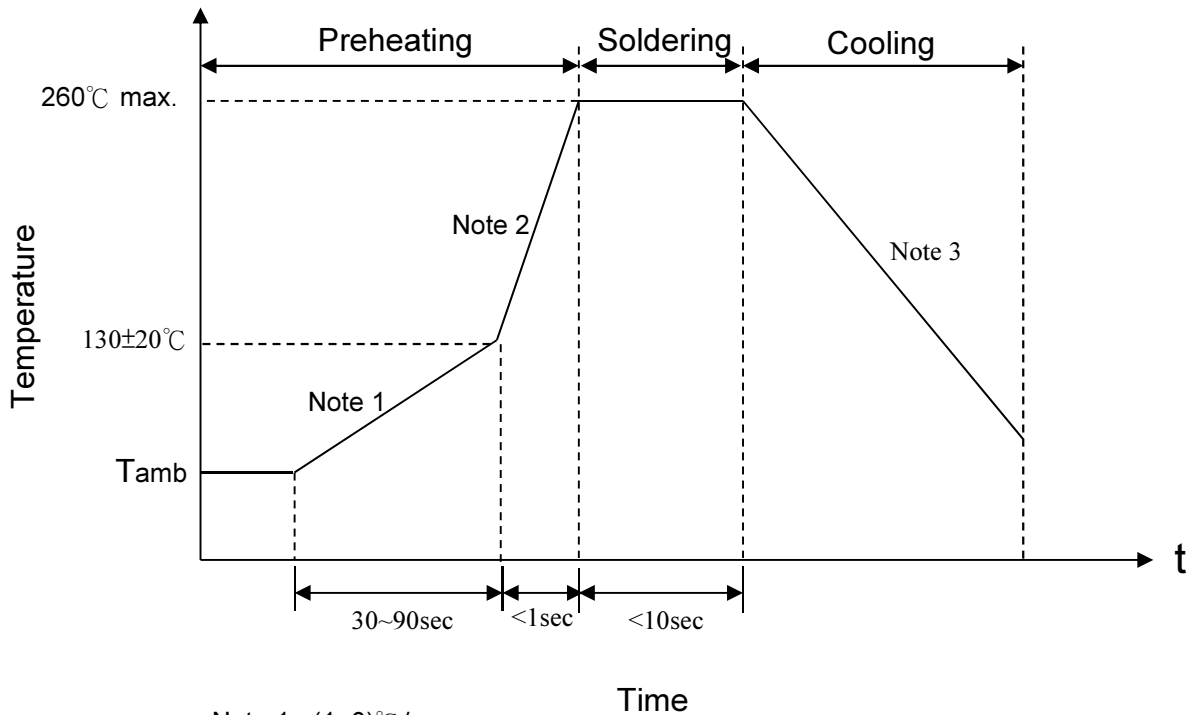

- Note 1 : (1~3)°C/sec
- Note 2 : Approx. 200°C/sec
- Note 3 : 5°C/sec Max

■ Recommended Reworking Conditions with Soldering Iron

Item	Conditions
Temperature of Soldering Iron-tip	360°C (max.)
Soldering Time	3 sec (max.)
Distance from Thermistor	2 mm (min.)

RoHS Compliant Declaration

We hereby declare that the components delivered to your company are compliant with RoHS directive 2015/863/EU.

Warehouse Storage Conditions of Products

(I) Storage Conditions :

- 1.Storage Temperature : $-10^{\circ}\text{C}\sim+40^{\circ}\text{C}$
- 2.Relative Humidity : $\leq 75\%RH$
- 3.Keep away from corrosive atmosphere and sunlight.

(II) Period of Storage : 1 year

Taping and Dimensions

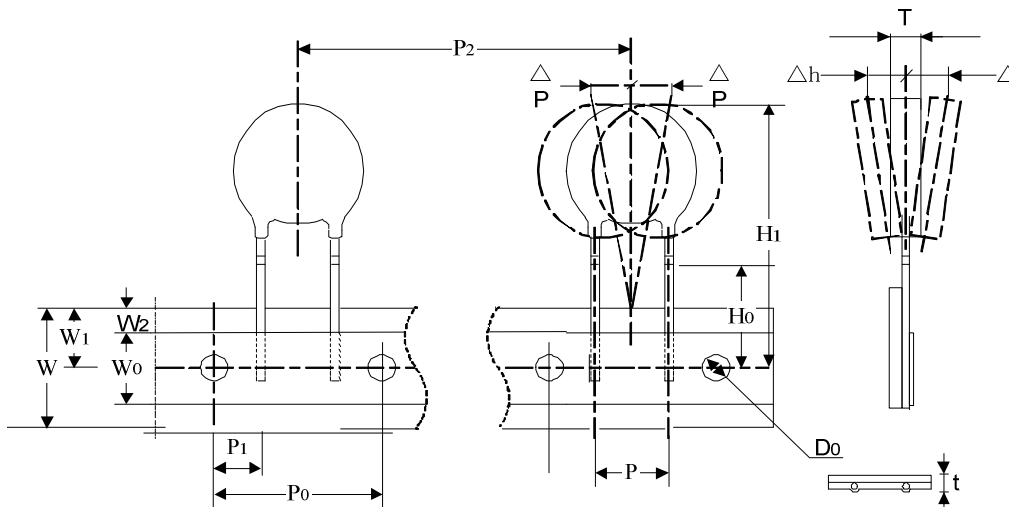

(unit : mm)

ITEM	P ₀	P	P ₁	H ₀	W ₀	W ₁	W	W ₂ max	T	ΔP max	Δh max	D ₀	t	P ₂	H ₁ max
Nor.	12.7	5	3.85	16	11.5	9	18	3	3.75	1.0	2.0	4	0.6	12.7	25
ToL.	±0.3	±1	±1	±0.5	±1.5	±1	±1	---	±0.75	---	---	±0.2	±0.2	±1	---

Standard Packing

(1) : Quantity (1500pcs / Ammo Box)

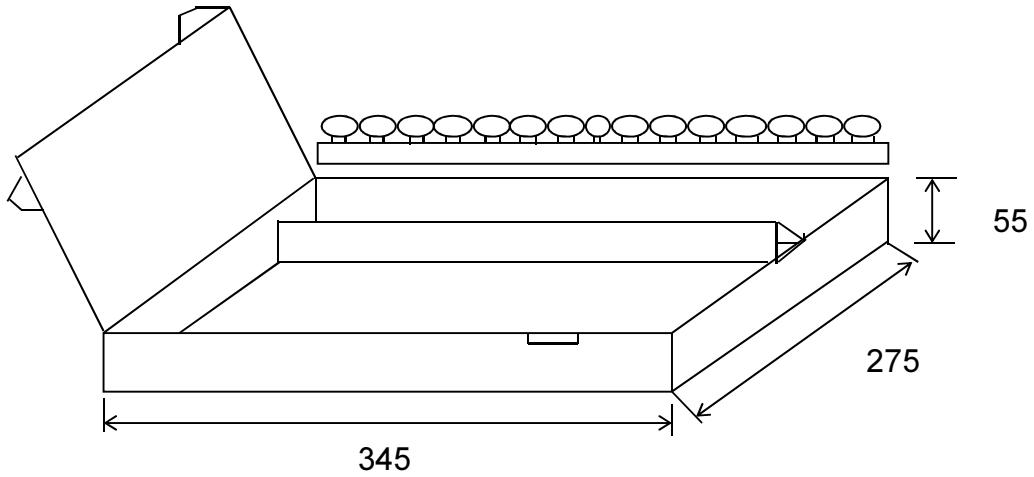

(2) : Quantity (5 Ammo Box / Carton)

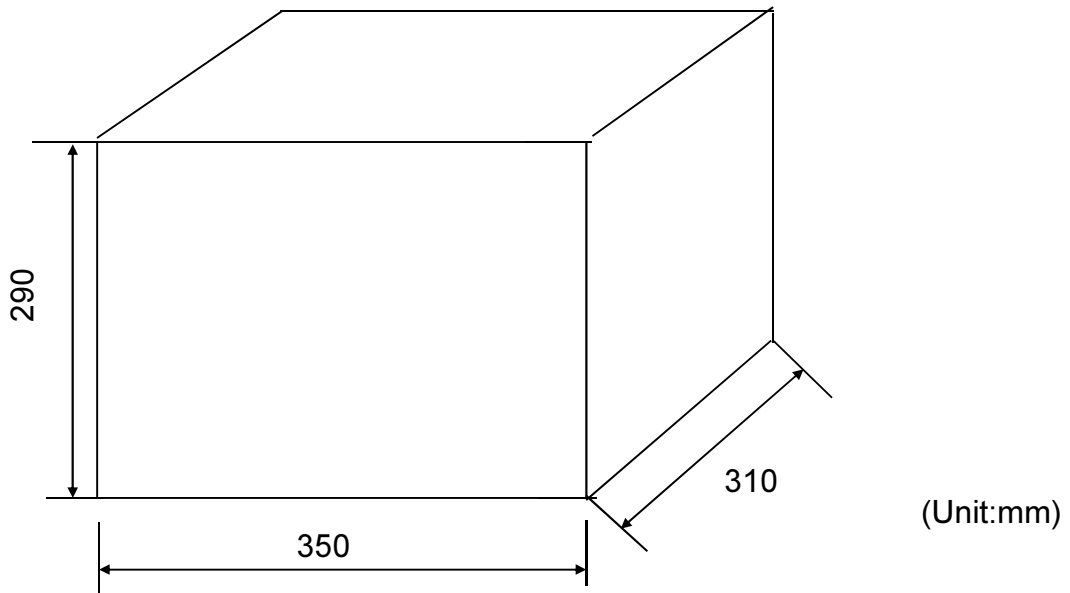



Certificates

- (1) IATF 16949 certificate
- (2) ISO 9001 certificate

Test Report

- (1) RoHS test report